

EVO-R



aera.com.tr | aerabim.com | aeracloud.com | aereselect.com

EVO-R units are used in environments where fresh air demand is high. These units are energy efficient, silent, fully automated with plug-and-play logic. Their compact structure allow them to be placed in mechanical spaces inside the buildings and also can be used in open environments such as roofs.

EVO-R Devices Significant Features

- 9 different models between 800-15000 m3/h flow rate scale,
- Very high aerodynamic efficiency via developed fan/motor design,

- EUROVENT certificated rotor exchanger up to 84% thermal and humidity efficiency (EN308),
- AZ150 coated internal/powder coated external sheet which has C4 corrosion resistance,
- High heat insulation and low internal leaks via special case design,
- Low internal pressure loss,
- SENSO+ automation system access to Cloud,
- Easy access to mechanical volumes in building via modular case structure.



EVO-R

COMPACT AIR HANDLING UNITS WITH
ROTARY HEAT EXCHANGER





CASING

EVO Compact Air Handling Unit's casings are engineered with today's standards, according to future needs. By eliminating the defects of traditional casings, high thermal and acoustical performance have been achieved, mechanical strength and corrosion resistance have been increased. As a result, a compact body that provides easy operation and service has emerged. Performance values were calculated prior to the actual product testing, using modern engineering methods developed by 3D computerized design and analysis during design stage. Subsequently, these values were verified with tests made in accordance with relevant standards in our modern testing laboratory.

the formation of thermal bridging are made up of sheet metals and sealing gaskets that are fixed on a specially designed PVC frame. Since the inner and outer panel sheets are not connected, thermal, leakage from metal surfaces is prevented. With the help of the PVC frame used, continuous and homogeneous insulation was obtained on the panels. With this structure on the sides of the panel, the thickness remain the same for each surface. The air gap in the PVC profile increases the thermal resistance of the profile and reduces the total heat transfer coefficient.

In EVO Compact Air Handling Units, unique panels with high thermal and air leakage resistance are used in fixed panels and service panels. Continuity is provided in the seals by special corner joining method. The panels to prevent

leakage resistance are used in fixed panels and service panels. Continuity is provided in the seals by special corner joining method. The panels to prevent

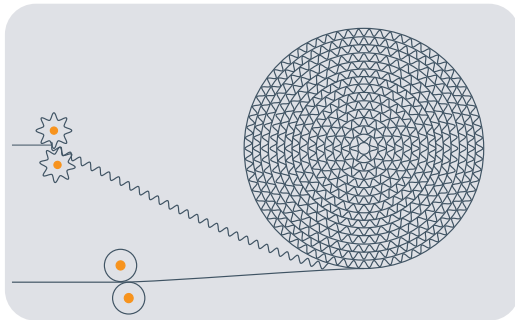

EXCHANGER

EVO-R Compact Air Conditioning Plants are produced with new materials and producing technologies. Heat transfer efficiency is reaching up to 84% in the heating and cooling seasons via high technology.

Steo motor which is used as rotor driver is suitable for automation, changes the speed according to heating and cooling needs so optimum energy recovery is provided. The step motor in use provides 55% energy saving compared with AC motors. The part in the rotor transfers the heat is called as matrix and occurs as high resistant Aluminium sheets shaped undulated rolling on each other. If the distance between the turns (vane distance) increase, transferring heat is decreasing with pressure drop, if the vane distance decrease, transferring heat is increasing with rotor pressure drop. For EVO-R Compact Air

Conditioning Plants condensing type rotor which has 1,6 mm vane distance as a standard is used. For higher heat transferring need 1,4 mm vane distance rotors or for low pressure drop need 1,8, 2,0 or 2,5 mm vane distance rotors can be used. Rotors can be produced as Condensing or Sorption type according to meet the purpose that different humidity transferring needs.

SELECTION SOFTWARE (aerselect.com)

There is selection software to calculate the EVO-r devices' performance results at the desired flow rates in the project. With the selection software from the address www.aerselect.com the devices can be selected easily suitable for the heating and cooling need with desired flow rate and the duct pressure. Devices automation and accessories can be defined via the software so, the device configuration is able to be done. Selection software can obtain the thermodynamic values, device measurements, ECO-DESIGN report and BIM file belongs to device as a print.

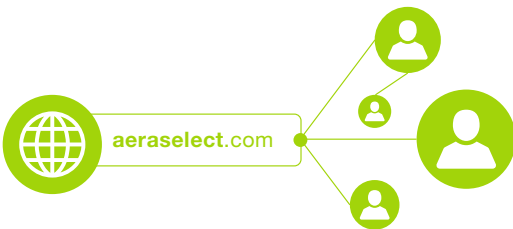

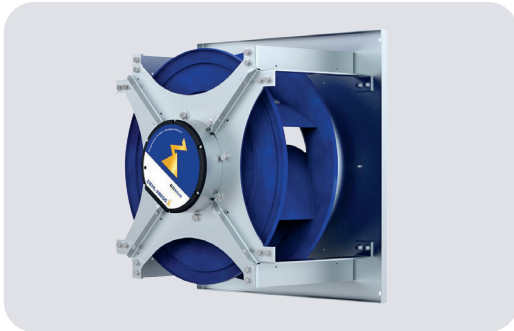

FAN

EVO Compact Air Handling Units are designed using plug type EC fans with high aerodynamic efficiency, low noise levels and low energy consumption. All fans meet ECO-DESIGN criteria set by the Energy Commission of the European Union and are compatible with ERP 2015. Plug fans with EC motors with the help of SENSO PLUS control system, can be driven steplessly with an indoor air quality sensor or with constant volume. Fans are ready to provide constant pressure in VAV systems with the VAV kit supplied as accessory. Plug type fans with EC motors are AC-powered fans with DC motor technology. The DC motor provides high electrical efficiency and can be connected to the AC mains with the converter located on them. It is perfectly matched to the high-tech electronic components used and magnetic noise transmitted to the network is prevented. EC motors communicate with the SENSO PLUS control system via Modbus.

This reduces the number of in-line cabling and provides more information to the user and ensures optimum operating point is used in the unit. The computerized analysis of the fan blades has made it possible to optimize the aerodynamic efficiency and reduce the sound levels. The back plate of the fan impeller has been redesigned for a linear air flow. The EC motors used perform well beyond today's efficiency requirements and all motors comply with the IE4 energy efficiency class.



FILTER

EVO-R devices, at the fresh air side ePM1 55% (F7) class, at the exhaust air side ePM10 50% (M5) class filters are comprised as a standard. By these high efficient filters as they are catching 90% of dust particles which have up to 0,4 μm radius, room air quality is increased. Filters have low starting pressure drop values because of having both their high efficiencies and increased surface area. In order to observe filter pollution differential pressure transmitters are applied at fresh air and exhaust air filters. Thus, as the filter's pressure drop is followed instantly, the used is acknowledged. For different flow rates, as different pressure drops are defined, the dynamic filter alarm can be created by SENSO PLUS. In the fresh air side of devices optionally ePM1 80% (F9) filter can be used.



BIM FILES

BIM files which belong to EVO-R devices are uploaded from the address www.aerabim.com at the revit software can be used automatically. In the same way, with Magiccloud software or its plug-in it is possible to reach BIM files.

SENSO+

The advanced control system SENSO PLUS in EVO-C Wheel Units, provides the most efficient control of all components which can be installed internally and as external accessories, ensuring the desired airflow conditions.

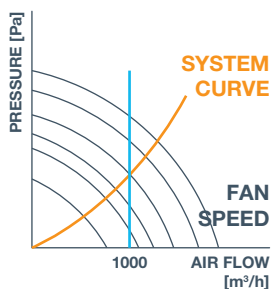

Constant Air Volume

To meet the desired constant airflow requirement in the EVO-C Handling Units, the SENSO PLUS control measures the air pressure drop in the suction ports of the fans and compares the air flow with the set value to produce a working signal that will change the EC fan fan speed.

Contamination of the filters can be controlled by static flow control within the fan operating curve, to the static pressure requirements of the unit which result in higher or lower than the project values.

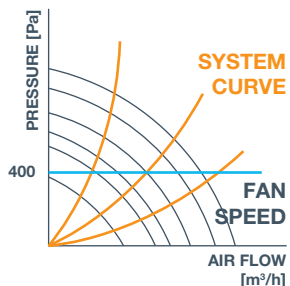

Constant Air Pressure

In EVO-C Units, constant pressure control is used to meet the variable airflow requirement of the air duct system. The SENSO PLUS control generates a working signal that will change the EC fan speed by continuously measuring the static pressure created in the supply air duct and comparing it with the value defined in the system. When a VAV damper opens or closes, higher or lower external static pressure needs can be met with constant pressure control within the fans operating curve. This way extreme noise in the ducts, unbalanced airflow distribution in different volumes is prevented.

ROTARY HEAT EXCHANGER CONTROL

In EVO R air handling units, rotary heat recovery exchanger is produced with a variable revolution rotor drive with SENSO PLUS control. By controlling the supply air temperature, the rotor revolution is automatically adjusted according to the required heat recovery. If the outside air conditions are appropriate, the rotor is stopped and free cooling is performed. An alarm signal is sent and the user is warned by the sensor attached to the device if the rotor does not rotate due to any malfunction. If the rotor is not spinning for 30 minutes due to suitable outdoor conditions, rotor will turn for 20 seconds at 12 rpm for automatic cleaning.

HUMIDITY CONTROL EQUIPMENT

Humidity control equipments are used to raise or lower the humidity of the supply air. With the SENSO PLUS control, the humidifier / dehumidifiers can be controlled to bring the supply air to the desired humidity value.

The SENSO PLUS control also provides system control besides equipment control, which means that the devices can be operated with the Yearly Timer Function according to the working periods: Daily, Weekly, Monthly or Yearly. In the Timer Function, values such as weekly working days, vacation times, daylight savings time can be defined and reported retrospectively.

Besides, the Support Function which is used to prevent the undesired conditions from occurring indoors even when the device is not working. The indoor temperature from falling below or exceeding a certain value even during non-working hours is ensured.

COOLING COIL

Externally mounted duct-type water cooling coils are used for such purposes as lowering the blowing temperature and dehumidifying the air in the units. It can be driven either proportionally or by on / off method.

Heating Coil

Heating coils are used for increasing the supply air temperature and for bringing the supply air to the desired temperature after dehumidifying process. Hot water coils can be driven by proportional control via 2 or 3 way valves. With the SENSO PLUS control, frost protection mechanism is available as standard to prevent the temperature of the supply water from reaching freezing conditions in extreme cold climates. If the return water temperature falls below a certain value set on the control, the heating valve is switched to the 100% open position and a run signal is sent to the heating water circulation pump. If the temperature still does not rise to the desired value, the device is stopped and the user is given a freeze alarm.

DX COIL

Externally mounted duct type DX batteries are used for purposes such as lowering the supply air temperature, dehumidifying process and bringing the blown air to the desired temperature after dehumidification. It can be step controlled with on / off method, maximum 8 step setting is available.

Indoor Air Quality Control

The air quality sensor or the CO2 sensor, which is placed in the critical volume or return channel in the interior, continuously measures the air quality. This value generates a signal that will change the EC fan speed by comparing it to the set point on the controller. If the indoor air quality is lower than the desired value, the fan speed and thus the fresh air amount is increased; if the indoor air quality is higher than the desired indoor air quality, the fan speed and fresh air speed are decreased; Energy saving is achieved in considerable amounts in heating or cooling loads caused by fresh air.

FILTER POLLUTION CHECK

The pressure drops of the filters used to clean the air, can be controlled by SENSO PLUS control. Users are notified about the filter cleaning and replacement intervals. Pressure drop control can be made according to a constant pressure drop (Static) or variable air flow (Dynamic). Especially with units designed with variable speed fans, Dynamic Filter Control enables filter service at the right time.

USER INTERFACE

With SENSO+ EVO ECO control panel which has buttons or EVO TOUCH 7" touch screen control panel is presented. Also there is a web server for observing or controlling the device which is integrated in the card. On the server the settings can be done, also both of the instantaneous operating values and history of operating values are able to be followed.



The web server on SENSO+, as connecting to web, via a computer/tablet or a mobile phone at anywhere in the world, operating situation can be viewed and the access for changing the settings is provided. Without needing a complex web settings, this feature can be activated with a simple web connected cable.

The devices in the different projects, with cumulating all of the devices in the same display, as it is synchronized, operating values, active alarms etc. values as followed and the settings can be changed if it is desired. Especially in the projects within the multiple devices or for servicing the multiple devices in different places this system is provided optionally together with SENSO+ .

COMMUNICATION OPTIONS

SENSO PLUS control supports all of the universal communication protocols and interacts with other air handling units as well as with other building automation systems. ModBUS, BACnet and EXOline protocols are open as standard and there is also possibility to connect with LONWORKS protocol as an option.



■ EVO-R (S) 15



■ FAN PERFORMANCE CURVES

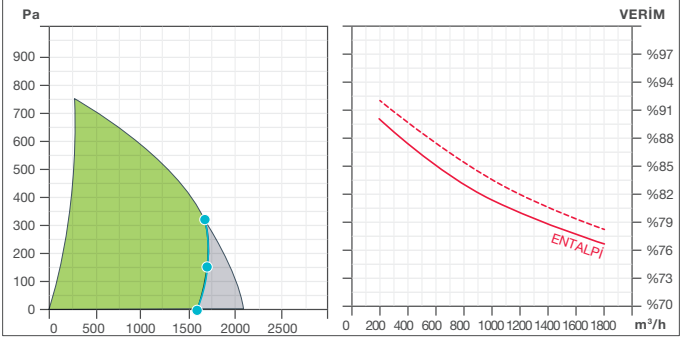

UNIT INFORMATION

	EVO-R (S) 15
Exchanger Type	Aluminum/Adsorption Rotor (5)
Fan Type	EC Plug Fan
ERP Compatibility	ERP 2018
Installation	Indoor / Outdoor (3)
Installation Position	Vertical
Service Location	Front and Rear surface (4)
Case structure	50 mm Insulated Double Walled

TECHNICAL INFORMATIONS

Minimum Flow Rate (m3/h)	260
Nominal Flow Rate (m3/h)	1720
Efficiency (EN 308)	81%
Efficiency (-5°C OA, 22°C 50%RH RA)	83%
Verim, Nem Transfer Verimi	83%
According to EN 1886 Case Features	D1/L1/TB2/T2
Fresh Air Filter	ePM1 55% (F7)
Exhaust Filter	ePM10 50% (M5)
Operating Temperature (1) (°C)	-20/+50
Protecting Class	IP 31

Electrical Informations

Communicating Informations	BACnet, Modbus TCP/IP
Supply Voltage	400V, 3~, 50 Hz
Total Power (1) (kW)	0,9
Maksimum Current (A)	5,6

Sound Information (2)

Sound Level at Supply (dBA)	72
Sound Level at Return (dBA)	65
Surrounding Sound 1m. Distance (dBA)	48
Surrounding Sound 3m. Distance (dBA)	38
Surrounding Sound 5m. Distance (dBA)	34

■ DIMENSIONS [mm]

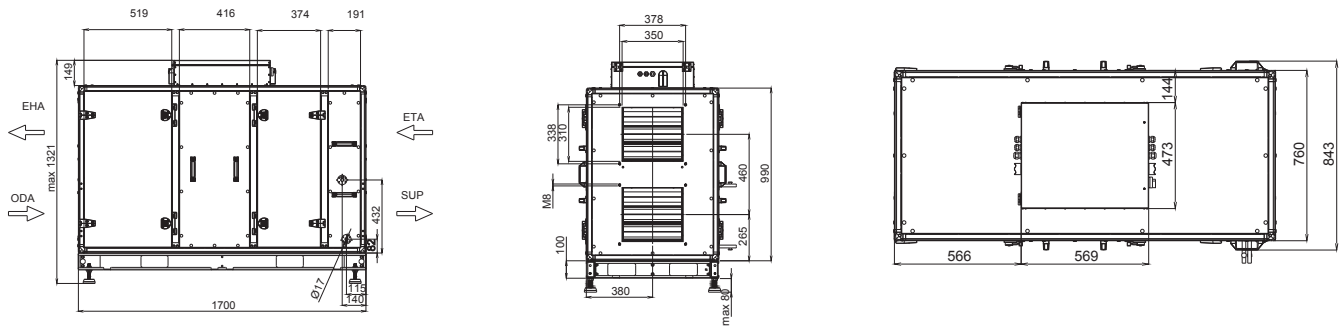

ACCESSORIES

Electric Pre Heater	Optional	External of device	Page 106
Electric After Heater	Optional	Internal of device	Page 06
Water After Heater	Optional	Internal of device	Page 107
Water Cooler	Optional	External of device	Page 107
Duct Connection Damper	Optional		Page 108
Outside Protection Sheet	Optional		Page 108
Fresh Air Spigot	Optional		Page 109
Exhaust Spigot	Optional		Page 109
Drainage Pump	Optional		Page 112
Bulk Siphon	Optional		Page 112
Room Control Panel Type1	EVO ECO		Page 112
Room Control Panel Type2	EVO TOUCH		Page 113
Room Control Panel Type3	-	-	
Cloud Connections Right	Optional		Page 111
VOD Sensor CO2	Optional		Page 110
VOD Sensor RH%	Optional		Page 110
VOD Sensor VOC	Optional		Page 110
Signal Converter	Optional		Page 111
Constant Pressure Kit	Optional		Page 111

Exhaust Filter Coarse	-	
Exhaust Filter ePM10 50%	Standard	
Fresh Air Filter Coarse	-	
Fresh Air Filter ePM10 50%	Optional	Page 110
Fresh Air Filter ePM1 55%	Standard	
Fresh Air Filter ePM1 80%	Optional	Page 110

- (1) Together with Electrical Preheater
- (2) As a result of the measurement according to ISO 5136
- (3) Outside Kit is used
- (4) Bidirectional installation is provided via service covers located at front and back
- (5) Humidity transfer is possible with the selection of Adsorption Rotor

■ EVO-R (S) 20



■ FAN PERFORMANCE CURVES

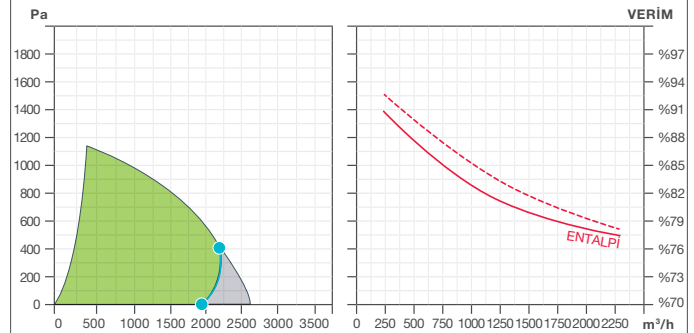

UNIT INFORMATION

	EVO-R (S) 20
Exchanger Type	Aluminum/Adsorption Rotor (5)
Fan Type	EC Plug Fan
ERP Compatibility	ERP 2018
Installation	Indoor / Outdoor (3)
Installation Position	Vertical
Service Location	Front and Rear surface (4)
Case structure	50 mm Insulated Double Walled

TECHNICAL INFORMATIONS

Minimum Flow Rate (m3/h)	310
Nominal Flow Rate (m3/h)	2210
Efficiency (EN 308)	80%
Efficiency (-5°C OA, 22°C 50%RH RA)	82%
Verim, Nem Transfer Verimi	82%
According to EN 1886 Case Features	D1/L1/TB2/T2
Fresh Air Filter	ePM1 55% (F7)
Exhaust Filter	ePM10 50% (M5)
Operating Temperature (1) (°C)	-20/+50
Protecting Class	IP 31

Electrical Informations

Communicating Informations	BACnet, Modbus TCP/IP
Supply Voltage	400V, 3~, 50 Hz
Total Power (1) (kW)	1
Maksimum Current (A)	4,4

Sound Information (2)

Sound Level at Supply (dBA)	74
Sound Level at Return (dBA)	65
Surrounding Sound 1m. Distance (dBA)	47
Surrounding Sound 3m. Distance (dBA)	38
Surrounding Sound 5m. Distance (dBA)	33

■ DIMENSIONS [mm]

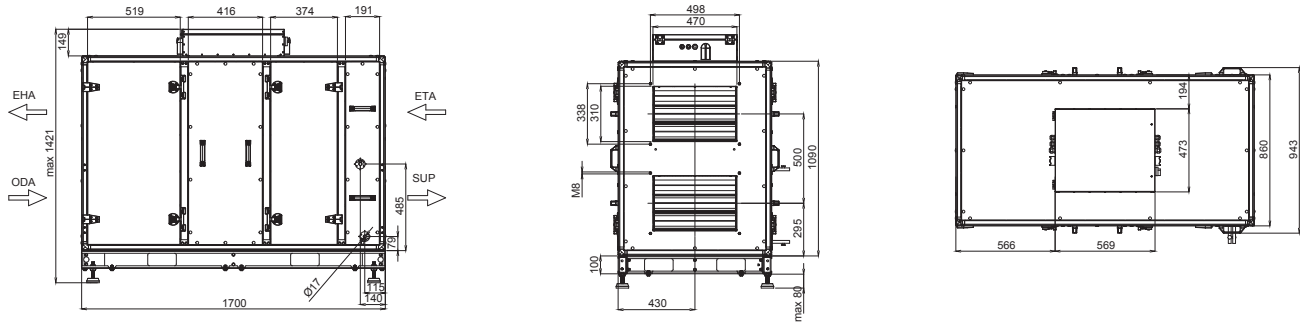

ACCESSORIES

Electric Pre Heater	Optional	External of device	Page 106
Electric After Heater	Optional	Internal of device	Page 06
Water After Heater	Optional	Internal of device	Page 107
Water Cooler	Optional	External of device	Page 107
Duct Connection Damper	Optional		Page 108
Outside Protection Sheet	Optional		Page 108
Fresh Air Spigot	Optional		Page 109
Exhaust Spigot	Optional		Page 109
Drainage Pump	Optional		Page 112
Bulk Siphon	Optional		Page 112
Room Control Panel Type1	EVO ECO		Page 112
Room Control Panel Type2	EVO TOUCH		Page 113
Room Control Panel Type3	-	-	
Cloud Connections Right	Optional		Page 111
VOD Sensor CO2	Optional		Page 110
VOD Sensor RH%	Optional		Page 110
VOD Sensor VOC	Optional		Page 110
Signal Converter	Optional		Page 111
Constant Pressure Kit	Optional		Page 111

Exhaust Filter Coarse	-
Exhaust Filter ePM10 50%	Standard
Fresh Air Filter Coarse	-
Fresh Air Filter ePM10 50%	Optional
Fresh Air Filter ePM1 55%	Standard
Fresh Air Filter ePM1 80%	Optional

- (1) Together with Electrical Preheater
- (2) As a result of the measurement according to ISO 5136
- (3) Outside Kit is used
- (4) Bidirectional installation is provided via service covers located at front and back
- (5) Humidity transfer is possible with the selection of Adsorption Rotor

■ EVO-R (S) 30



■ FAN PERFORMANCE CURVES

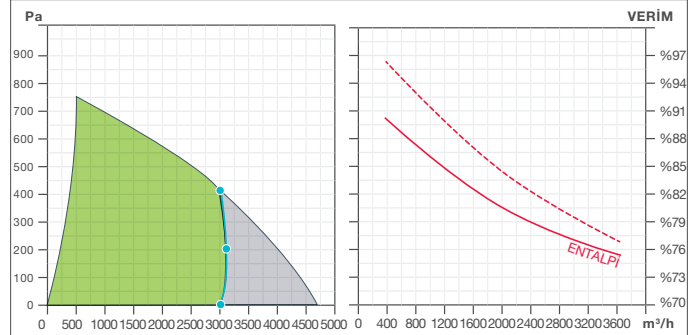

UNIT INFORMATION

	EVO-R (S) 30
Exchanger Type	Aluminum/Adsorption Rotor (5)
Fan Type	EC Plug Fan
ERP Compatibility	ERP 2018
Installation	Indoor / Outdoor (3)
Installation Position	Vertical
Service Location	Front and Rear surface (4)
Case structure	50 mm Insulated Double Walled

TECHNICAL INFORMATIONS

Minimum Flow Rate (m3/h)	480
Nominal Flow Rate (m3/h)	3160
Efficiency (EN 308)	78%
Efficiency (-5°C OA, 22°C 50%RH RA)	80%
Verim, Nem Transfer Verimi	80%
According to EN 1886 Case Features	D1/L1/TB2/T2
Fresh Air Filter	ePM1 55% (F7)
Exhaust Filter	ePM10 50% (M5)
Operating Temperature (1) (°C)	-20/+50
Protecting Class	IP 31

Electrical Informations

Communicating Informations	BACnet, Modbus TCP/IP
Supply Voltage	400V, 3~, 50 Hz
Total Power (1) (kW)	2
Maksimum Current (A)	3,3

Sound Information (2)

Sound Level at Supply (dBA)	82
Sound Level at Return (dBA)	74
Surrounding Sound 1m. Distance (dBA)	56
Surrounding Sound 3m. Distance (dBA)	46
Surrounding Sound 5m. Distance (dBA)	42

■ DIMENSIONS [mm]

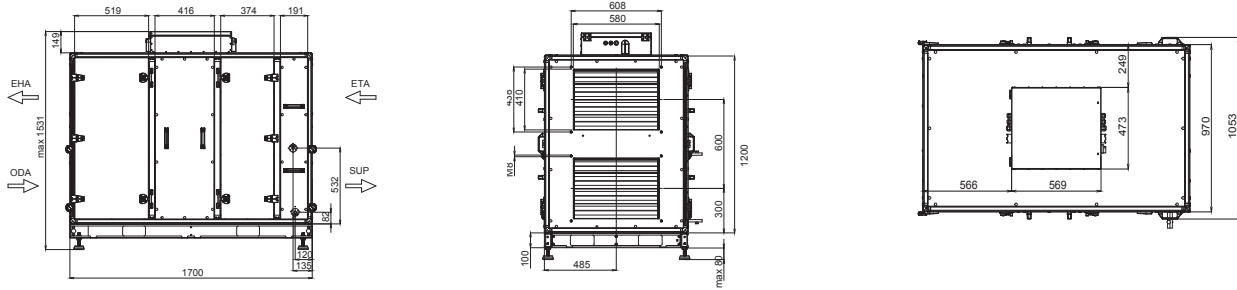

ACCESSORIES

Electric Pre Heater	Optional	External of device	Page 106
Electric After Heater	Optional	Internal of device	Page 06
Water After Heater	Optional	Internal of device	Page 107
Water Cooler	Optional	External of device	Page 107
Duct Connection Damper	Optional		Page 108
Outside Protection Sheet	Optional		Page 108
Fresh Air Spigot	Optional		Page 109
Exhaust Spigot	Optional		Page 109
Drainage Pump	Optional		Page 112
Bulk Siphon	Optional		Page 112
Room Control Panel Type1	EVO ECO		Page 112
Room Control Panel Type2	EVO TOUCH		Page 113
Room Control Panel Type3	-	-	
Cloud Connections Right	Optional		Page 111
VOD Sensor CO2	Optional		Page 110
VOD Sensor RH%	Optional		Page 110
VOD Sensor VOC	Optional		Page 110
Signal Converter	Optional		Page 111
Constant Pressure Kit	Optional		Page 111

Exhaust Filter Coarse	-	
Exhaust Filter ePM10 50%	Standard	
Fresh Air Filter Coarse	-	
Fresh Air Filter ePM10 50%	Optional	Page 110
Fresh Air Filter ePM1 55%	Standard	
Fresh Air Filter ePM1 80%	Optional	Page 110

- (1) Together with Electrical Preheater
- (2) As a result of the measurement according to ISO 5136
- (3) Outside Kit is used
- (4) Bidirectional installation is provided via service covers located at front and back
- (5) Humidity transfer is possible with the selection of Adsorption Rotor

■ EVO-R (S) 50



■ FAN PERFORMANCE CURVES

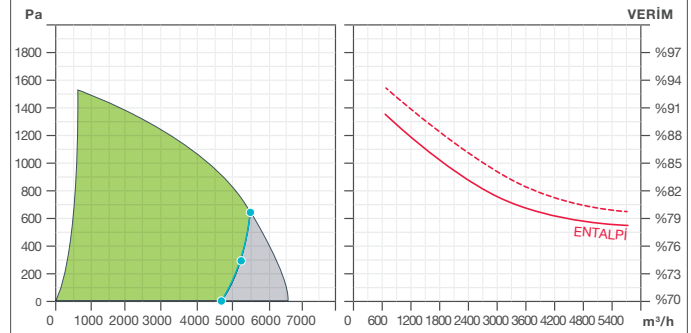

UNIT INFORMATION

	EVO-R (S) 50
Exchanger Type	Aluminum/Adsorption Rotor (5)
Fan Type	EC Plug Fan
ERP Compatibility	ERP 2018
Installation	Indoor / Outdoor (3)
Installation Position	Vertical
Service Location	Front and Rear surface (4)
Case structure	50 mm Insulated Double Walled

TECHNICAL INFORMATIONS

Minimum Flow Rate (m3/h)	690
Nominal Flow Rate (m3/h)	5180
Efficiency (EN 308)	79%
Efficiency (-5°C OA, 22°C 50%RH RA)	81%
Verim, Nem Transfer Verimi	81%
According to EN 1886 Case Features	D1/L1/TB2/T2
Fresh Air Filter	ePM1 55% (F7)
Exhaust Filter	ePM10 50% (M5)
Operating Temperature (1) (°C)	-20/+50
Protecting Class	IP 31

Electrical Informations

Communicating Informations	BACnet, Modbus TCP/IP
Supply Voltage	400V, 3~, 50 Hz
Total Power (1) (kW)	3,4
Maksimum Current (A)	5,2

Sound Information (2)

Sound Level at Supply (dBA)	80
Sound Level at Return (dBA)	70
Surrounding Sound 1m. Distance (dBA)	54
Surrounding Sound 3m. Distance (dBA)	45
Surrounding Sound 5m. Distance (dBA)	40

■ DIMENSIONS [mm]

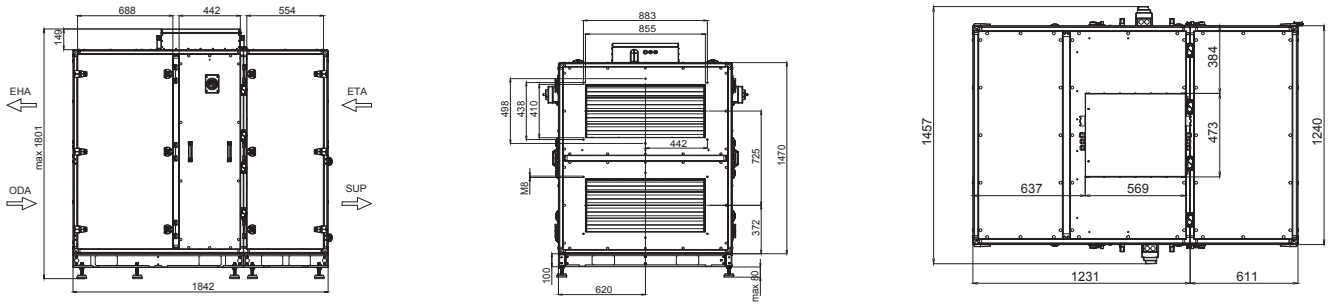

ACCESSORIES

Electric Pre Heater	Optional	External of device	Page 106
Electric After Heater	Optional	Internal of device	Page 06
Water After Heater	Optional	Internal of device	Page 107
Water Cooler	Optional	External of device	Page 107
Duct Connection Damper	Optional		Page 108
Outside Protection Sheet	Optional		Page 108
Fresh Air Spigot	Optional		Page 109
Exhaust Spigot	Optional		Page 109
Drainage Pump	Optional		Page 112
Bulk Siphon	Optional		Page 112
Room Control Panel Type1	EVO ECO		Page 112
Room Control Panel Type2	EVO TOUCH		Page 113
Room Control Panel Type3	-	-	
Cloud Connections Right	Optional		Page 111
VOD Sensor CO2	Optional		Page 110
VOD Sensor RH%	Optional		Page 110
VOD Sensor VOC	Optional		Page 110
Signal Converter	Optional		Page 111
Constant Pressure Kit	Optional		Page 111

Exhaust Filter Coarse	-	
Exhaust Filter ePM10 50%	Standard	
Fresh Air Filter Coarse	-	
Fresh Air Filter ePM10 50%	Optional	Page 110
Fresh Air Filter ePM1 55%	Standard	
Fresh Air Filter ePM1 80%	Optional	Page 110

- (1) Together with Electrical Preheater
- (2) As a result of the measurement according to ISO 5136
- (3) Outside Kit is used
- (4) Bidirectional installation is provided via service covers located at front and back
- (5) Humidity transfer is possible with the selection of Adsorption Rotor

■ EVO-R (S) 60



■ FAN PERFORMANCE CURVES

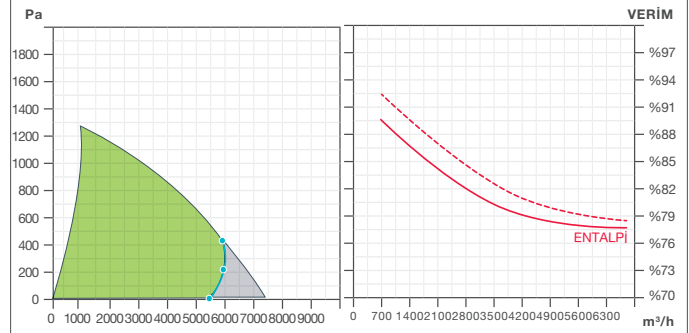

UNIT INFORMATION

	EVO-R (S) 60
Exchanger Type	Aluminum/Adsorption Rotor (5)
Fan Type	EC Plug Fan
ERP Compatibility	ERP 2018
Installation	Indoor / Outdoor (3)
Installation Position	Vertical
Service Location	Front and Rear surface (4)
Case structure	50 mm Insulated Double Walled

TECHNICAL INFORMATIONS

Minimum Flow Rate (m3/h)	840
Nominal Flow Rate (m3/h)	6120
Efficiency (EN 308)	80%
Efficiency (-5°C OA, 22°C 50%RH RA)	82%
Verim, Nem Transfer Verimi	82%
According to EN 1886 Case Features	D1/L1/TB2/T2
Fresh Air Filter	ePM1 55% (F7)
Exhaust Filter	ePM10 50% (M5)
Operating Temperature (1) (°C)	-20/+50
Protecting Class	IP 31

Electrical Informations

Communicating Informations	BACnet, Modbus TCP/IP
Supply Voltage	400V, 3~, 50 Hz
Total Power (1) (kW)	3,7
Maksimum Current (A)	5,8

Sound Information (2)

Sound Level at Supply (dBA)	79
Sound Level at Return (dBA)	70
Surrounding Sound 1m. Distance (dBA)	53
Surrounding Sound 3m. Distance (dBA)	44
Surrounding Sound 5m. Distance (dBA)	39

■ DIMENSIONS [mm]

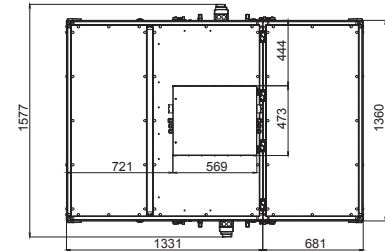
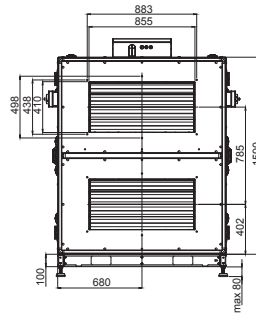
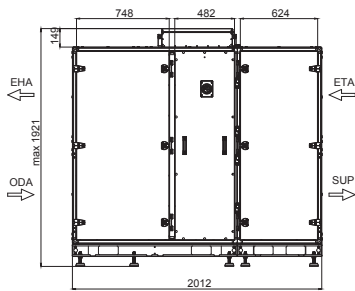

ACCESSORIES

Electric Pre Heater	Optional	External of device	Page 106
Electric After Heater	Optional	Internal of device	Page 06
Water After Heater	Optional	Internal of device	Page 107
Water Cooler	Optional	External of device	Page 107
Duct Connection Damper	Optional		Page 108
Outside Protection Sheet	Optional		Page 108
Fresh Air Spigot	Optional		Page 109
Exhaust Spigot	Optional		Page 109
Drainage Pump	Optional		Page 112
Bulk Siphon	Optional		Page 112
Room Control Panel Type1	EVO ECO		Page 112
Room Control Panel Type2	EVO TOUCH		Page 113
Room Control Panel Type3	-	-	
Cloud Connections Right	Optional		Page 111
VOD Sensor CO2	Optional		Page 110
VOD Sensor RH%	Optional		Page 110
VOD Sensor VOC	Optional		Page 110
Signal Converter	Optional		Page 111
Constant Pressure Kit	Optional		Page 111

Exhaust Filter Coarse	-	
Exhaust Filter ePM10 50%	Standard	
Fresh Air Filter Coarse	-	
Fresh Air Filter ePM10 50%	Optional	Page 110
Fresh Air Filter ePM1 55%	Standard	
Fresh Air Filter ePM1 80%	Optional	Page 110

- (1) Together with Electrical Preheater
- (2) As a result of the measurement according to ISO 5136
- (3) Outside Kit is used
- (4) Bidirectional installation is provided via service covers located at front and back
- (5) Humidity transfer is possible with the selection of Adsorption Rotor

■ EVO-R (S) 80



■ FAN PERFORMANCE CURVES

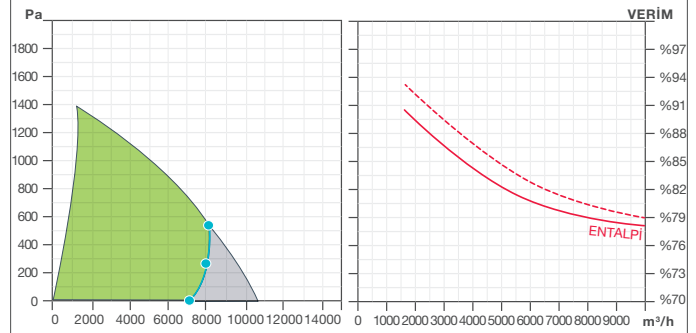

UNIT INFORMATION

	EVO-R (S) 80
Exchanger Type	Aluminum/Adsorption Rotor (5)
Fan Type	EC Plug Fan
ERP Compatibility	ERP 2018
Installation	Indoor / Outdoor (3)
Installation Position	Vertical
Service Location	Front and Rear surface (4)
Case structure	50 mm Insulated Double Walled

TECHNICAL INFORMATIONS

Minimum Flow Rate (m3/h)	1160
Nominal Flow Rate (m3/h)	8090
Efficiency (EN 308)	79%
Efficiency (-5°C OA, 22°C 50%RH RA)	81%
Verim, Nem Transfer Verimi	81%
According to EN 1886 Case Features	D1/L1/TB2/T2
Fresh Air Filter	ePM1 55% (F7)
Exhaust Filter	ePM10 50% (M5)
Operating Temperature (1) (°C)	-20/+50
Protecting Class	IP 31

Electrical Informations

Communicating Informations	BACnet, Modbus TCP/IP
Supply Voltage	400V, 3~, 50 Hz
Total Power (1) (kW)	5,3
Maksimum Current (A)	8

Sound Information (2)

Sound Level at Supply (dBA)	83
Sound Level at Return (dBA)	72
Surrounding Sound 1m. Distance (dBA)	57
Surrounding Sound 3m. Distance (dBA)	48
Surrounding Sound 5m. Distance (dBA)	43

■ DIMENSIONS [mm]

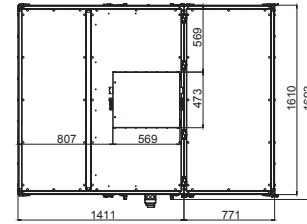
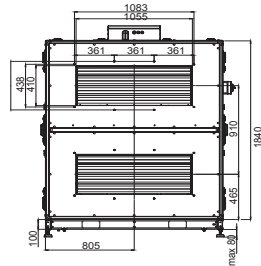
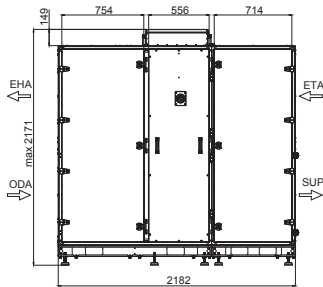

ACCESSORIES

Electric Pre Heater	Optional	External of device	Page 106
Electric After Heater	Optional	Internal of device	Page 06
Water After Heater	Optional	Internal of device	Page 107
Water Cooler	Optional	External of device	Page 107
Duct Connection Damper	Optional		Page 108
Outside Protection Sheet	Optional		Page 108
Fresh Air Spigot	Optional		Page 109
Exhaust Spigot	Optional		Page 109
Drainage Pump	Optional		Page 112
Bulk Siphon	Optional		Page 112
Room Control Panel Type1	EVO ECO		Page 112
Room Control Panel Type2	EVO TOUCH		Page 113
Room Control Panel Type3	-	-	
Cloud Connections Right	Optional		Page 111
VOD Sensor CO2	Optional		Page 110
VOD Sensor RH%	Optional		Page 110
VOD Sensor VOC	Optional		Page 110
Signal Converter	Optional		Page 111
Constant Pressure Kit	Optional		Page 111

Exhaust Filter Coarse	-	
Exhaust Filter ePM10 50%	Standard	
Fresh Air Filter Coarse	-	
Fresh Air Filter ePM10 50%	Optional	Page 110
Fresh Air Filter ePM1 55%	Standard	
Fresh Air Filter ePM1 80%	Optional	Page 110

- (1) Together with Electrical Preheater
- (2) As a result of the measurement according to ISO 5136
- (3) Outside Kit is used
- (4) Bidirectional installation is provided via service covers located at front and back
- (5) Humidity transfer is possible with the selection of Adsorption Rotor

■ EVO-R (S) 95



■ FAN PERFORMANCE CURVES

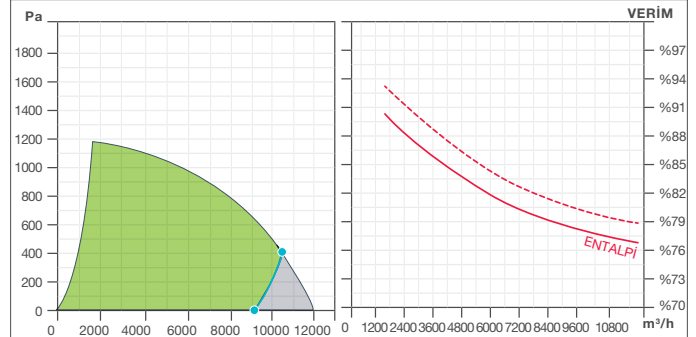

UNIT INFORMATION

	EVO-R (S) 95
Exchanger Type	Aluminum/Adsorption Rotor (5)
Fan Type	EC Plug Fan
ERP Compatibility	ERP 2018
Installation	Indoor / Outdoor (3)
Installation Position	Vertical
Service Location	Front and Rear surface (4)
Case structure	50 mm Insulated Double Walled

TECHNICAL INFORMATIONS

Minimum Flow Rate (m3/h)	1640
Nominal Flow Rate (m3/h)	10400
Efficiency (EN 308)	78%
Efficiency (-5°C OA, 22°C 50%RH RA)	81%
Verim, Nem Transfer Verimi	80%
According to EN 1886 Case Features	D1/L1/TB2/T2
Fresh Air Filter	ePM1 55% (F7)
Exhaust Filter	ePM10 50% (M5)
Operating Temperature (1) (°C)	-20/+50
Protecting Class	IP 31

Electrical Informations

Communicating Informations	BACnet, Modbus TCP/IP
Supply Voltage	400V, 3~, 50 Hz
Total Power (1) (kW)	6,9
Maksimum Current (A)	10,6

Sound Information (2)

Sound Level at Supply (dBA)	81
Sound Level at Return (dBA)	72
Surrounding Sound 1m. Distance (dBA)	56
Surrounding Sound 3m. Distance (dBA)	47
Surrounding Sound 5m. Distance (dBA)	42

■ DIMENSIONS [mm]

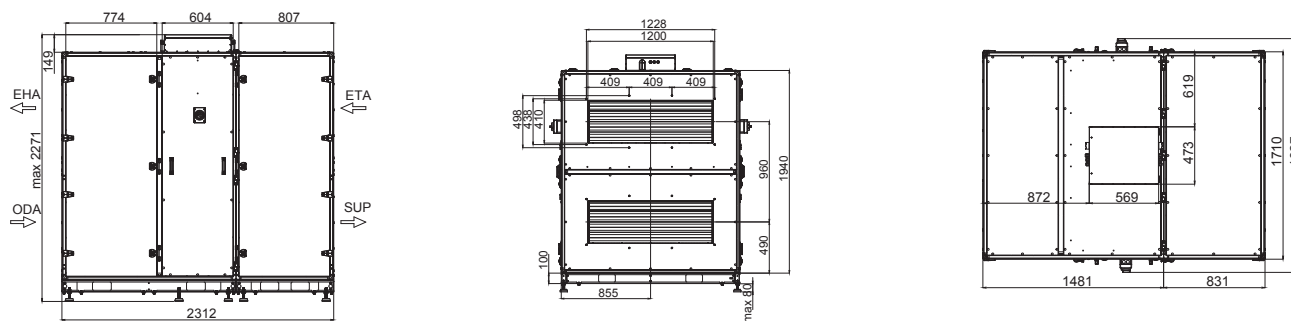

ACCESSORIES

Electric Pre Heater	Optional	External of device	Page 106
Electric After Heater	Optional	Internal of device	Page 06
Water After Heater	Optional	Internal of device	Page 107
Water Cooler	Optional	External of device	Page 107
Duct Connection Damper	Optional		Page 108
Outside Protection Sheet	Optional		Page 108
Fresh Air Spigot	Optional		Page 109
Exhaust Spigot	Optional		Page 109
Drainage Pump	Optional		Page 112
Bulk Siphon	Optional		Page 112
Room Control Panel Type1	EVO ECO		Page 112
Room Control Panel Type2	EVO TOUCH		Page 113
Room Control Panel Type3	-	-	
Cloud Connections Right	Optional		Page 111
VOD Sensor CO2	Optional		Page 110
VOD Sensor RH%	Optional		Page 110
VOD Sensor VOC	Optional		Page 110
Signal Converter	Optional		Page 111
Constant Pressure Kit	Optional		Page 111

Exhaust Filter Coarse	-	
Exhaust Filter ePM10 50%	Standard	
Fresh Air Filter Coarse	-	
Fresh Air Filter ePM10 50%	Optional	Page 110
Fresh Air Filter ePM1 55%	Standard	
Fresh Air Filter ePM1 80%	Optional	Page 110

- (1) Together with Electrical Preheater
- (2) As a result of the measurement according to ISO 5136
- (3) Outside Kit is used
- (4) Bidirectional installation is provided via service covers located at front and back
- (5) Humidity transfer is possible with the selection of Adsorption Rotor

■ EVO-R (S) 120



■ FAN PERFORMANCE CURVES

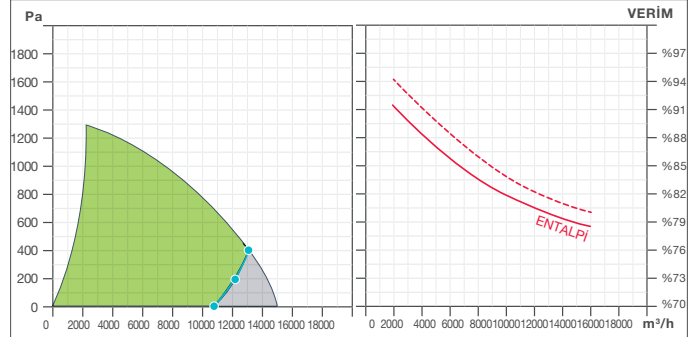

UNIT INFORMATION

	EVO-R (S) 120
Exchanger Type	Aluminum/Adsorption Rotor (5)
Fan Type	EC Plug Fan
ERP Compatibility	ERP 2018
Installation	Indoor / Outdoor (3)
Installation Position	Vertical
Service Location	Front and Rear surface (4)
Case structure	50 mm Insulated Double Walled

TECHNICAL INFORMATIONS

Minimum Flow Rate (m3/h)	2000
Nominal Flow Rate (m3/h)	12980
Efficiency (EN 308)	79%
Efficiency (-5°C OA, 22°C 50%RH RA)	81%
Verim, Nem Transfer Verimi	81%
According to EN 1886 Case Features	D1/L1/TB2/T2
Fresh Air Filter	ePM1 55% (F7)
Exhaust Filter	ePM10 50% (M5)
Operating Temperature (1) (°C)	-20/+50
Protecting Class	IP 31

Electrical Informations

Communicating Informations	BACnet, Modbus TCP/IP
Supply Voltage	400V, 3~, 50 Hz
Total Power (1) (kW)	9,4
Maksimum Current (A)	14,4

Sound Information (2)

Sound Level at Supply (dBA)	82
Sound Level at Return (dBA)	74
Surrounding Sound 1m. Distance (dBA)	57
Surrounding Sound 3m. Distance (dBA)	47
Surrounding Sound 5m. Distance (dBA)	43

■ DIMENSIONS [mm]

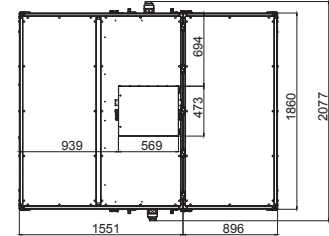
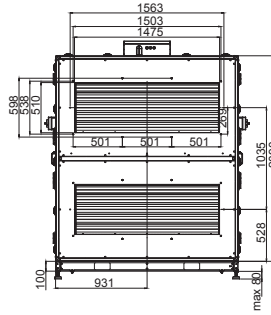
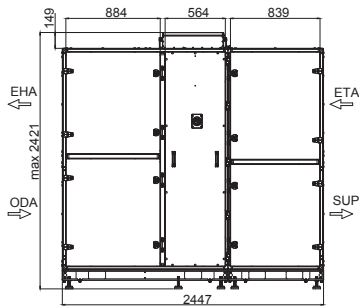

ACCESSORIES

Electric Pre Heater	Optional	External of device	Page 106
Electric After Heater	Optional	Internal of device	Page 06
Water After Heater	Optional	Internal of device	Page 107
Water Cooler	Optional	External of device	Page 107
Duct Connection Damper	Optional		Page 108
Outside Protection Sheet	Optional		Page 108
Fresh Air Spigot	Optional		Page 109
Exhaust Spigot	Optional		Page 109
Drainage Pump	Optional		Page 112
Bulk Siphon	Optional		Page 112
Room Control Panel Type1	EVO ECO		Page 112
Room Control Panel Type2	EVO TOUCH		Page 113
Room Control Panel Type3	-	-	
Cloud Connections Right	Optional		Page 111
VOD Sensor CO2	Optional		Page 110
VOD Sensor RH%	Optional		Page 110
VOD Sensor VOC	Optional		Page 110
Signal Converter	Optional		Page 111
Constant Pressure Kit	Optional		Page 111

Exhaust Filter Coarse	-	
Exhaust Filter ePM10 50%	Standard	
Fresh Air Filter Coarse	-	
Fresh Air Filter ePM10 50%	Optional	Page 110
Fresh Air Filter ePM1 55%	Standard	
Fresh Air Filter ePM1 80%	Optional	Page 110

- (1) Together with Electrical Preheater
- (2) As a result of the measurement according to ISO 5136
- (3) Outside Kit is used
- (4) Bidirectional installation is provided via service covers located at front and back
- (5) Humidity transfer is possible with the selection of Adsorption Rotor

■ EVO-R (S) 150



■ FAN PERFORMANCE CURVES

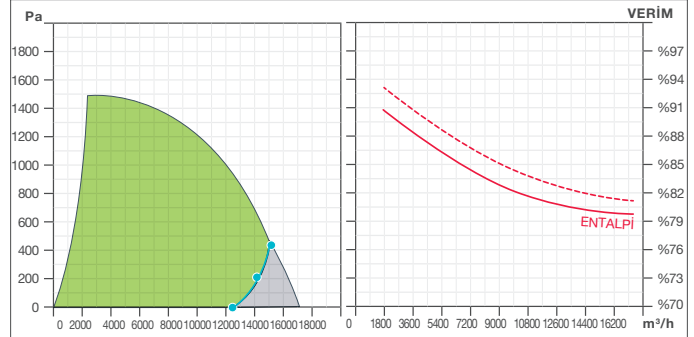

UNIT INFORMATION

	EVO-R (S) 150
Exchanger Type	Aluminum/Adsorption Rotor (5)
Fan Type	EC Plug Fan
ERP Compatibility	ERP 2018
Installation	Indoor / Outdoor (3)
Installation Position	Vertical
Service Location	Front and Rear surface (4)
Case structure	50 mm Insulated Double Walled

TECHNICAL INFORMATIONS

Minimum Flow Rate (m3/h)	2190
Nominal Flow Rate (m3/h)	15400
Efficiency (EN 308)	80%
Efficiency (-5°C OA, 22°C 50%RH RA)	82%
Verim, Nem Transfer Verimi	82%
According to EN 1886 Case Features	D1/L1/TB2/T2
Fresh Air Filter	ePM1 55% (F7)
Exhaust Filter	ePM10 50% (M5)
Operating Temperature (1) (°C)	-20/+50
Protecting Class	IP 31

Electrical Informations

Communicating Informations	BACnet, Modbus TCP/IP
Supply Voltage	400V, 3~, 50 Hz
Total Power (1) (kW)	10
Maksimum Current (A)	15,4

Sound Information (2)

Sound Level at Supply (dBA)	84
Sound Level at Return (dBA)	76
Surrounding Sound 1m. Distance (dBA)	59
Surrounding Sound 3m. Distance (dBA)	50
Surrounding Sound 5m. Distance (dBA)	45

■ DIMENSIONS [mm]

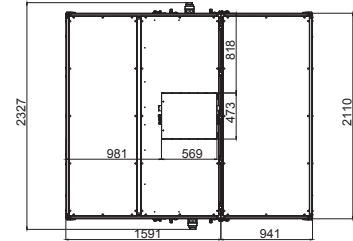
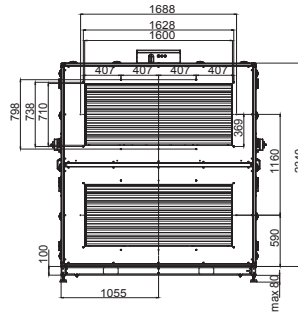
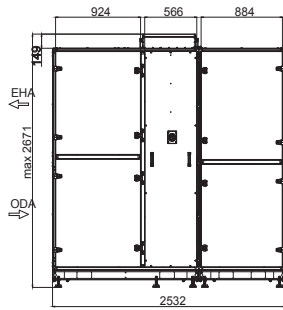

ACCESSORIES

Electric Pre Heater	Optional	External of device	Page 106
Electric After Heater	Optional	Internal of device	Page 06
Water After Heater	Optional	Internal of device	Page 107
Water Cooler	Optional	External of device	Page 107
Duct Connection Damper	Optional		Page 108
Outside Protection Sheet	Optional		Page 108
Fresh Air Spigot	Optional		Page 109
Exhaust Spigot	Optional		Page 109
Drainage Pump	Optional		Page 112
Bulk Siphon	Optional		Page 112
Room Control Panel Type1	EVO ECO		Page 112
Room Control Panel Type2	EVO TOUCH		Page 113
Room Control Panel Type3	-	-	
Cloud Connections Right	Optional		Page 111
VOD Sensor CO2	Optional		Page 110
VOD Sensor RH%	Optional		Page 110
VOD Sensor VOC	Optional		Page 110
Signal Converter	Optional		Page 111
Constant Pressure Kit	Optional		Page 111

Exhaust Filter Coarse	-	
Exhaust Filter ePM10 50%	Standard	
Fresh Air Filter Coarse	-	
Fresh Air Filter ePM10 50%	Optional	Page 110
Fresh Air Filter ePM1 55%	Standard	
Fresh Air Filter ePM1 80%	Optional	Page 110

- (1) Together with Electrical Preheater
- (2) As a result of the measurement according to ISO 5136
- (3) Outside Kit is used
- (4) Bidirectional installation is provided via service covers located at front and back
- (5) Humidity transfer is possible with the selection of Adsorption Rotor

ACCESSORIES

■ ELECTRICAL PREHEATER

Used in order to prevent freezing at the exchanger in the situations which the outside air is very low. Controlled as a single step with SENSO control. Provides controllable energy efficiency with SENSO+ control via proportional signal.

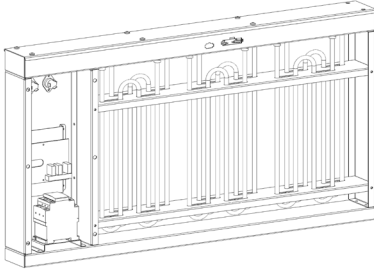

Model	Heater Capacity (kW)	Current (A)	Control
ER-PREH 1500	4,2	6,1	Oransal
ER-PREH 2000	5,8	8,4	Oransal
ER-PREH 3000	9,1	13,2	Oransal
ER-PREH 5000	15,6	22,7	Oransal
ER-PREH 6000	18,1	26,3	Oransal
ER-PREH 8000	22	32,0	Oransal
ER-PREH 9500	22	32,0	Oransal
ER-PREH 12000	22	32,0	Oransal
ER-PREH 15000	22	32,0	Oransal

■ ELECTRICAL AFTER HEATER

Used for increasing the supply air temperature. Operates automatically according to desired room temperature or desired supply temperature. Controlled as a single step with SENSO control. Provides controllable energy efficiency with SENSO+ control via proportional signal.

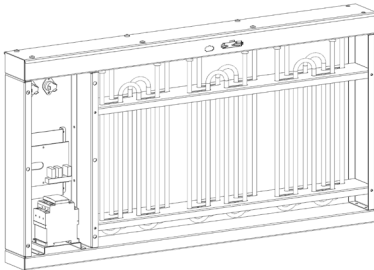

Model	Heater Capacity (kW)	Current (A)	Control
ER-POEH 1500*	4,2	6,1	Oransal
ER-POEH 2000*	5,8	8,4	Oransal
ER-POEH 3000*	9,1	13,2	Oransal
ER-POEH 5000	15,6	22,7	Oransal
ER-POEH 6000	18,1	26,3	Oransal
ER-POEH 8000	22	32,0	Oransal
ER-POEH 9500	22	32,0	Oransal
ER-POEH 12000	22	32,0	Oransal
ER-POEH 15000	22	32,0	Oransal

* Cihaz içine uygulanabilmektedir.

■ WATER COOLING

Used for cooling inside, water type cooling batteries are existed as accesories. With SENSO+ control, controlled proportionally according to desired supply temperature or desired room temperature.

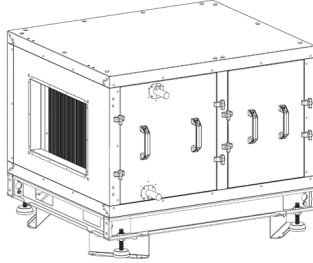

* Cihaz içine uygulanabilmektedir.

Model	Heater Capacity (kW)	Water Regime	Control
ER-POWH 1500*	4,2	80-60	Oransal
ER-POWH 2000*	5,8	80-60	Oransal
ER-POWH 3000*	9,1	80-60	Oransal
ER-POWH 5000	15,6	80-60	Oransal
ER-POWH 6000	18,1	80-60	Oransal
ER-POWH 8000	22	80-60	Oransal
ER-POWH 9500	22	80-60	Oransal
ER-POWH 12000	22	80-60	Oransal
ER-POWH 15000	22	80-60	Oransal

■ WATER AFTER HEATER

Used for increasing the supply air temperature. Operates automatically according to desired room temperature or desired supply temperature. Controlled as a single step with SENSO control. Provides controllable energy efficiency with SENSO+ control via proportional signal.

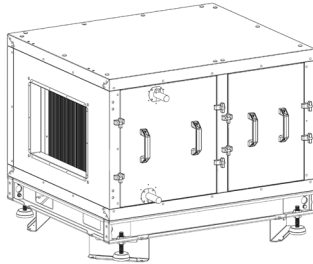

Model	Heater Capacity (kW)	Water Regime	Control
ER-KR 1500	4,5	7-12	Oransal
ER-KR 2000	4,5	7-12	Oransal
ER-KR 3000	6	7-12	Oransal
ER-KR 5000	9	7-12	Oransal
ER-KR 6000	15	7-12	Oransal
ER-KR 8000	18	7-12	Oransal
ER-KR 9500	21	7-12	Oransal
ER-KR 12000	24	7-12	Oransal
ER-KR 15000	30	7-12	Oransal

ACCESSORIES

■ Duct Connection Damper

The motor operated damper, as turned itself off when the devices is turned off, prevent the leakage can be occurred via air duct. It can be implemented in or out of device. Has the Class 3 impermeability as a standard.

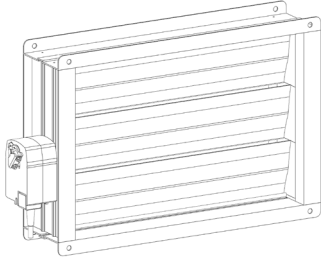

Model	Heater Capacity (kW)	Current (A)	Control
ER-DAMP 1500*	40...75 s	24C DC , yay geri dönüşlü	Oransal
ER-DAMP 2000*	40...75 s	24C DC , yay geri dönüşlü	Oransal
ER-DAMP 3000*	40...75 s	24C DC , yay geri dönüşlü	Oransal
ER-DAMP 5000	40...75 s	24C DC , yay geri dönüşlü	Oransal
ER-DAMP 6000	40...75 s	24C DC , yay geri dönüşlü	Oransal
ER-DAMP 8000	40...75 s	24C DC , yay geri dönüşlü	Oransal
ER-DAMP 9500	40...75 s	24C DC , yay geri dönüşlü	Oransal
ER-DAMP 12000	40...75 s	24C DC , yay geri dönüşlü	Oransal
ER-DAMP 15000	40...75 s	24C DC , yay geri dönüşlü	Oransal

* Cihaz içine uygulanabilmektedir.

■ Outdoor Protection Sheet

If the devices are used outdoors, they are used for water insulation. The devices thus achieve the insulation class IP 54.



Model
ER-WPC 1500
ER-WPC 2000
ER-WPC 3000
ER-WPC 5000
ER-WPC 6000
ER-WPC 8000
ER-WPC 9500
ER-WPC 12000
ER-WPC 15000

■ **Fresh Air Spigot :**

Is used as connected to fresh air duct of devices installed at the areas open to atmosphere and prevent the water to enter in device by drift eliminator on the device.

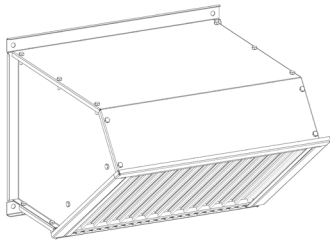

Model
ER-FAS 1500
ER-FAS 2000
ER-FAS 3000
ER-FAS 5000
ER-FAS 6000
ER-FAS 8000
ER-FAS 9500
ER-FAS 12000
ER-FAS 15000

■ **Exhaust Air Spigot**

Is used as connected to exhaust air duct of devices at the areas open to atmosphere and prevent the water to enter in device.

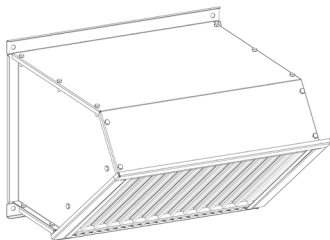

Model
ER-FAS 1500
ER-FAS 2000
ER-FAS 3000
ER-FAS 5000
ER-FAS 6000
ER-FAS 8000
ER-FAS 9500
ER-FAS 12000
ER-FAS 15000

ACCESSORIES

■ FILTER

In the projects, it is designed as a standard for more sensitive than the present filter's filtering

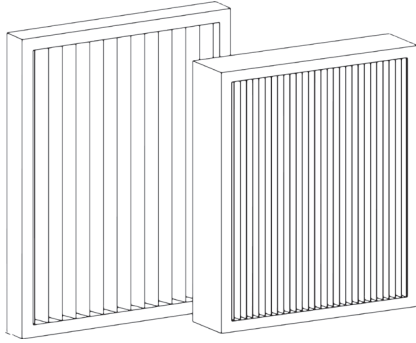

Model	Code
Taze Hava filtresi ePM10 50%	ER15FAEPM10-50
	ER20FAEPM10-50
	ER30FAEPM10-50
	ER50FAEPM10-50
	ER60FAEPM10-50
	ER80FAEPM10-50
	ER95FAEPM10-50
	ER120FAEPM10-50
	ER150FAEPM10-50
Taze Hava filtresi ePM1 80%	ER15FAEPM1-80
	ER20FAEPM1-80
	ER30FAEPM1-80
	ER50FAEPM1-80
	ER60FAEPM1-80
	ER80FAEPM1-80
	ER95FAEPM1-80
	ER120FAEPM1-80
	ER150FAEPM1-80

■ VOD

Located in inside of critical volume or return duct, the optional air quality sensor (VOC or CO₂) or relative humidity sensor (RH%) consistently measures the air quality or relative humidity. This value, as being compared with set value which is arranged on control, creates operating which changes EC fan's fan speed. If the air in room is lower than desired air quality or the relative humidity is higher than the desired value, the fan speed is increased so, fresh air amount increased, if the air in room is higher than desired air quality or the relative humidity is lower than the desired value, the fan speed is decreased so, fresh air amount decreased; Thus, a significant energy save is provided at the heating or cooling loads caused by the fresh air.



Model	Measurement	Installation Position
VOD-VOC-RM	VOC	Room
VOD-VOC-DUCT	VOC	Channel
VOD-CO ₂ -DUCT	CO ₂	Room
VOD-CO ₂ -RM	CO ₂	Channel
VOD-RH-DUCT	RH%	Room
VOD-RH-RM	RH%	Channel
PS-MW	-	-

■ CLOUD CONNECTION

The web server on SENSO+, as connecting to web, via a computer/tablet or a mobile phone at anywhere in the world, operating situation can be viewed and the access for changing the settings is provided. Without needing a complex web settings, this feature can be activated with a simple web connected cable.



Model
SENSO+ CLOUD

■ Constant Pressure Kit

Used for serving the purpose of ventilation system's varying flow rate. SENSO+, creates the signal which can change EC fan's fan speed as measuring static pressure value consistently, as comparing with defined value to the system. Turning up or down the VAV damper which are different volume in duct system, serve the purpose of static pressure out of device as a result of higher or lower values than projected values with constant pressure control. In the fan operating characteristic, extreme volume sound occurred in the ducts and flow rate in different volumes are prevented.



Model
SENSO-CAP

■ Signal Converter

SENSO+ devices as make an access that connect up to 3 VOD sensors, both measure gas and different volume gases, change the capacity according to these measurements of air conditioning plants. Via Signal Converter, in 3 different types, for each type up to 6 measurements or obtained values from 18 different measurement volumes are used for controlling air conditioning plant is provided.



Model
SENSO+ SK

ACCESSORIES

■ BALL SIPHON

Used for disposal of water in the heat recovery sections, the result of condensation at the exhaust air or the result of condensation at the cooking batteries. Can operate in both positive negative pressure.

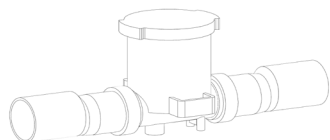

Model
SIPH

■ Drainage Pump

Used when unloading the water occurred from condensation at the exchanger or battery cell in the device not possible via the present slope.

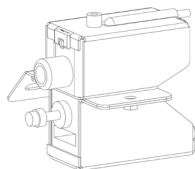

Model	Maximum Flow (l/h)	Max Head (m)	Max Suction Height (m)	Energy Supply
DP 01	13	10	1,5	230 V, 50/60 Hz
DP 02	40	10	2	230 V, 50/60 Hz

■ EVO-ECO

Is a user panel used as a user interface in the devices has the SENSO+ control card. Connected to control panel via 4x0.75 cable or RJ-12 Jack.



Model
EVO-ECO

■ **EVO-TOUCH**

Is a 7" sized touch type user panel used as a user interface. Connected to control panel via 4x0.75 cable or RJ-12 Jack.



Model

EVO-TOUCH



SEPTEMBER 2019
THE MANUFACTURER RESERVES THE RIGHT TO CHANGE THE SPECIFICATION WITHOUT PRIOR NOTICE.

AERA İKLİMLENDİRME TEKNOLOJİLERİ SAN. VE TİC. AŞ

SALES OFFICE Varyap Meridian, Grand Tower A Blok No:130 Ataşehir, İSTANBUL - TR

TEL +90 216 504 76 86 FAX +90 216 504 76 90

FACTORY 3. Cadde No:13 Pancar OSB, Torbalı, İzmir - TR

TEL +90 232 799 0 111 FAX +90 232 799 01 14 E-MAIL info@aera.com.tr

R&D CENTER 3. Cadde No:13 Pancar OSB, Torbalı, İzmir - TR

