

Breathing Innovation into Ventilation!

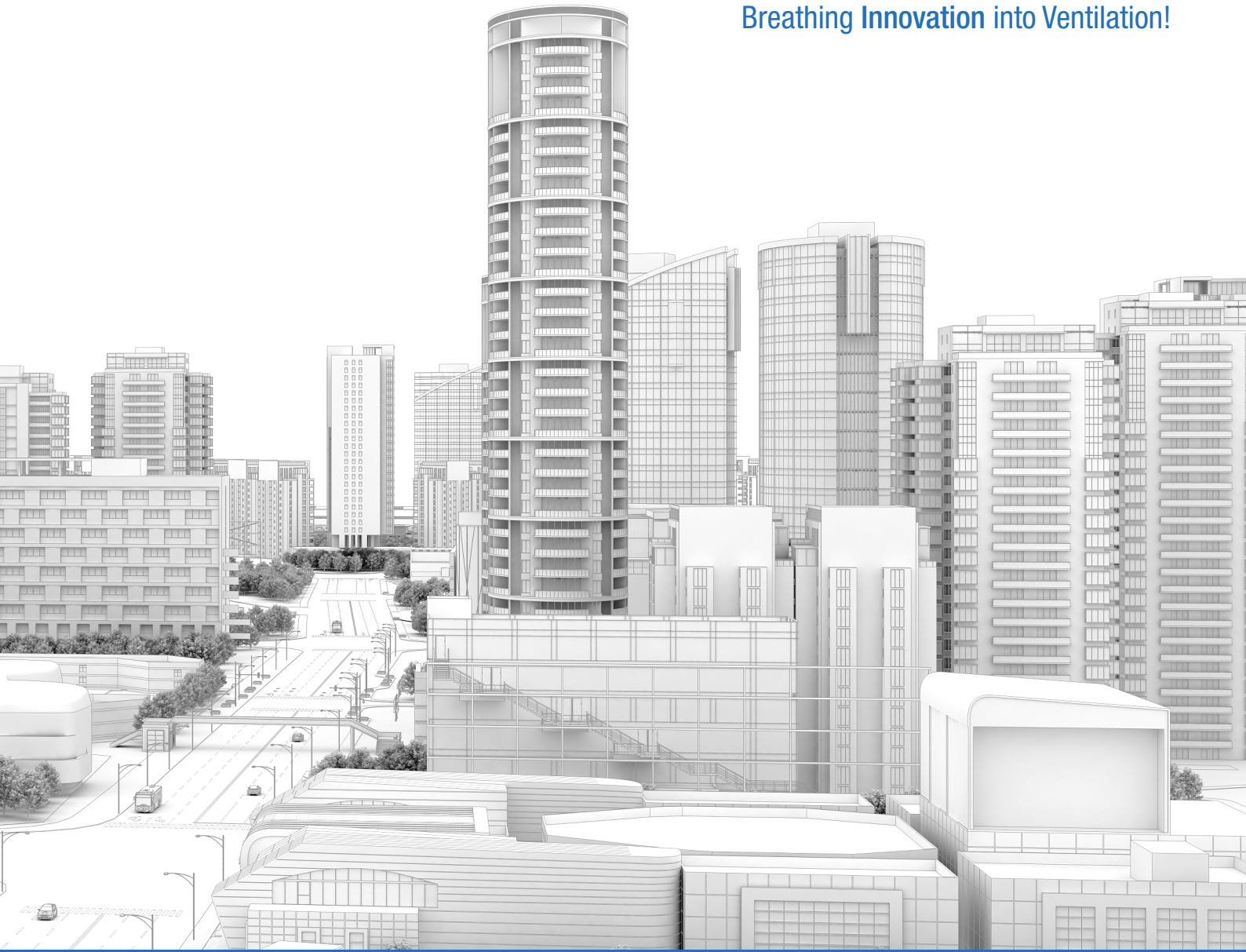

VESTA HR  
CROSS FLOW  
HEAT RECOVERY VENTILATION

[aera.com.tr](http://aera.com.tr)







## INDEX

ABOUT US.....	Page 4-7
COMPACT AIR HANDLING UNITS.....	Page 8-15
ANEMO Test Lab.....	Page 16-17
CERTIFICATION.....	Page 18-19
SENSO+ CONTROL.....	Page 20-21
VESTA.....	Page 22-37



## AERA is wherever you breathe fresh!

- Offices
- Restaurants
- Hotels
- Cafes
- Shopping Malls
- Exhibition Halls
- Industrial Buildings
- Museums
- Laboratories
- Markets
- Hospitals
- Malls
- Nursing Homes
- Schools and Universities
- Conference Halls
- Stadiums and Sports Halls
- Concert Halls
- Stations and Airports
- Banks



## Inspiring Confidence, Powering Progress Globally

AERA products have achieved a global presence, captivating markets across Europe, the Middle East, and beyond.







Welcome to AERA



**Breathing Innovation into Ventilation!**

Born in the innovative surroundings of the Bilimpark – Science and Technology Development Zone, AERA started with a dedicated Product Development Team with a simple mission: to enhance air quality everywhere.

**2016** In 2016, we moved to our foundational facility in Pancar Industrial Zone. Covering over 3,000 m2, this space is equipped with modern machinery, ensuring our products meet the highest standards and reach you efficiently.

That same year, we established our domestic sales office in Istanbul, marking our commitment to serve both local and international customers.

**2017** was a pivotal year for us as we introduced our Modular Air Handling Units and Heat Recovery Ventilators to the market. By mid-2017, we began our journey towards achieving international certifications, ensuring our solutions stand up to global standards.

By the close of 2017, AERA broadened its portfolio with the introduction of the Compact Air Handling Units family. This range catered to diverse needs, including horizontal units for ceiling mounting and versatile standing units, both with plate and rotary heat recovery options.



Our commitment to innovation didn't stop there. In collaboration with a leading AHU Control Components manufacturer, we co-developed distinctive air handling unit controls. These state-of-the-art controls, conceived and crafted through international expertise, made their debut in the market the very same year.

**2018** Recognizing the burgeoning industry demand and our ever-growing aspirations, 2018 was a significant milestone: We acquired a spacious factory land spanning 10,000 m2, setting the stage for further advancements and the promise of bringing even more refined ventilation solutions to our valued clientele.

The journey of AERA has always been marked by innovation and collaboration. A testament to this is our pioneering partnership with TUBITAK (Turkey's Scientific and Technological Research Council). This collaboration bore fruit in the form of our first government-subsidized development project. Our unique product designs further paved the way for us to receive State Funds, establishing our R&D Centre of Excellence.

**Our commitment to excellence was recognized globally in 2018 when EUROVENT certified our modular AHU range. This acknowledgment, particularly for outstanding casing performance (T2/TB2, EN 1886), set us apart. That year, our drive for innovation continued unabated, with the inception of development projects centered around panel casing design and ceiling-mounted air handling units equipped with rotary wheels.**

**AERA's name has grown to resonate powerfully, both within Turkish borders and beyond.**

**Our distinction lies not just in our products but also in our unparalleled service offerings. This has enabled us to stand tall, often being the preferred choice over renowned competitors for state-of-the-art design projects.**

**2021** In a pivotal move at the end of 2021, we saw the completion of our new production plant. This state-of-the-art facility now houses the majority of our production activities and operational offices, reflecting our relentless pursuit of growth and excellence.

**2023** **In the quest for healthier indoor spaces, we've made a major stride!**

We are proud to announce a significant achievement in our commitment to quality and health: our Air Handling Units have earned the **Hygienic Certificate from TÜV SÜD.**



With AERA, it's always about bringing cleaner, fresher air to spaces everywhere. We're here to serve, innovate, and grow alongside our community. AERA started with a dedicated Product Development Team with a simple mission: to enhance air quality everywhere.

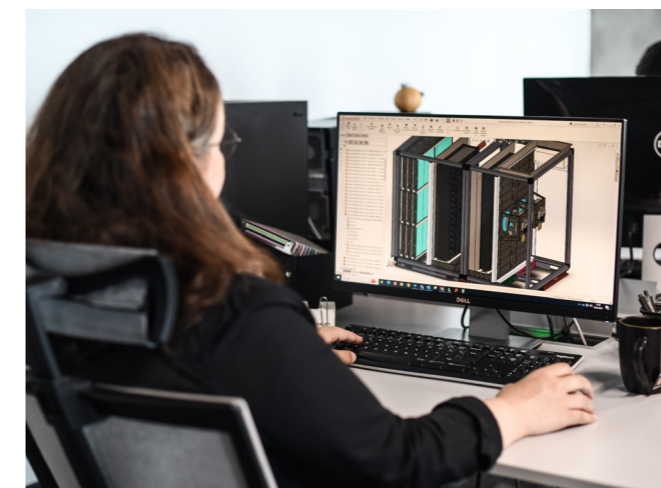



AERA Compact Air Handling Units efficiently supply conditioned outdoor air to meet specific requirements while simultaneously expelling indoor air. They achieve exceptional heat and energy efficiency through advanced counterflow or rotary heat recovery heat exchangers.



**Why go Compact?**

**Why not?**

Compact Air Handling Units, provide unique solutions in ventilation applications with their high energy efficiency, low noise levels, and ease of installation and operation.

**INDEPENDANT, LOCAL VENTILATION SOLUTION**

- Localized solutions with airflow rates of up to 15,000 m<sup>3</sup>/h can be created with independant duct and distribution systems, ensuring ease of operation.
- Efficient solutions tailored to specific needs can be provided for variable demands depending on building facade and usage purpose.



**Efficient Space Utilization and Cost Optimization.**

**ENHANCED LIVING / USAGE SPACE IN BUILDINGS**

- Thanks to their compact design, they do not require large mechanical spaces/volumes.
- Ceiling-mounted compact air handling units can increase living spaces by utilizing suitable areas such as wet rooms and corridors.
- Floor-mounted compact air handling units can provide solutions in small/narrow mechanical spaces.
- They will eliminate the need for several vertical shafts and large duct dimensions. Two main ducts for outdoor and exhaust air and local duct and air distribution systems will be sufficient.



**Installation: Simplified!**

- Designed using high-efficiency, low-noise EC plug fans for enhanced aerodynamic efficiency. Equipped with fresh air and return air filters in compliance with ECO-DESIGN requirements.
- Deliver tailored solutions with heating, cooling, and humidification components, mounted on the unit casing and/or duct system, while providing operational ease through integrated controls.
- Thanks to its Plug-and-Play design, it is user-friendly, offering easy installation, quick commissioning, and BMS integration.
- Its compact structure, which takes up less space and offers alternative duct connection solutions, provides idealized solutions for commercial spaces, residences, office buildings, hotels, schools, and more.





Thanks to their space saving design, compact air handling units provide **flawless solutions** for commercial spaces, residences, office buildings, hotels, schools, banks, and other structures.



Our Compact Air Conditioning Units elegantly blend with your space, thanks to their minimalist footprint and quiet operation. They create operational efficiency with high energy efficiency and provide you with **top-tier comfort in indoor air quality!**





- ✗ More operating costs!
- ✗ More time and additional costs for installation, commissioning, and air adjustment!
- ✗ Larger mechanical space demand
- ✗ Increased visual congestion

**LESS LIVING SPACE, MORE MECHANICAL SPACE!**



✗ More labor and assembly costs



**Additional requirements for precise air adjustment:**

- ✗ CAV Box
- ✗ VAV Box
- ✗ Regulation Dampers



✗ The need for large air ducts for supply and exhaust, mechanical shaft space demand, results in large non-commercialized spaces

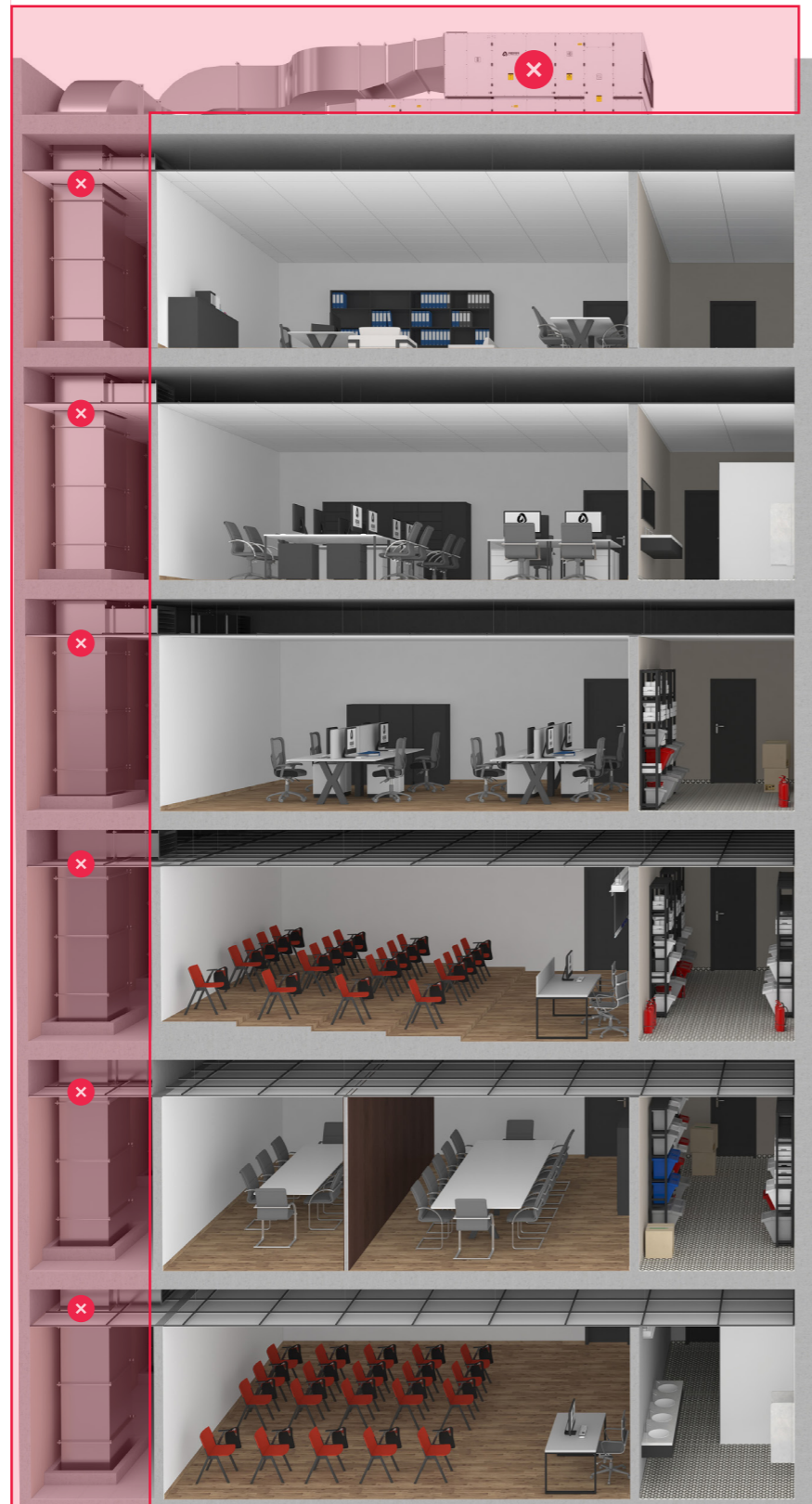

- ✓ Achieve lower energy consumption with easy plug-and-play installation.
- ✓ These units can be discreetly integrated into living spaces.
- ✓ Additional social spaces. Compact Air Handling Units can utilize the usage of terraces for green coverings such as gravel, grass, and similar natural materials, creating enjoyable living areas.

**MORE LIVING SPACE, LESS MECHANICAL VOLUME!**

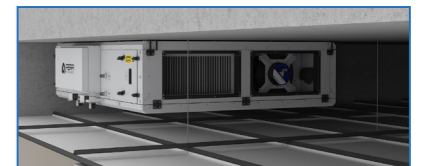

✓ By implementing them as suspended ceiling units, there is a substantial increase in commercial living space.



✓ They also offer the flexibility of placement in compact and multi-purpose volumes.



Compact Air Handling units are designed with high aerodynamic efficiency, utilizing EC Motors with Plug Fans to achieve **low noise levels and low energy** consumption.

**HIGH EFFICIENCY / OPERATIONAL ECONOMY**

- They offer up to **93%** temperature efficiency with counterflow or rotary heat recovery heat exchangers.
- Additionally, they provide up to **75%** humidity transfer ratio with sorption-type rotary heat recovery.
- Thanks to their high efficiency, they reduce the need for cooling and heating, enabling solutions with smaller capacities. This leads to reduced requirements of both equipment and labor for heating & cooling systems, pumps, pipes, insulation and system accessories.
- The use of IE4 efficiency class EC fans with aerodynamic design results in energy savings compared to other fan types.

**LOW NOISE LEVELS**

- Aerodynamic EC fans are used to reduce sound power levels.
- The double-walled casing structure and rock wool insulation contribute to environmental noise reduction.

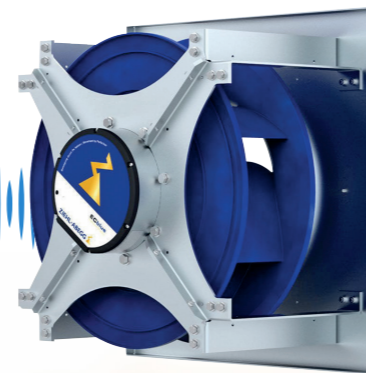

Remote connectivity with AERA Cloud

**SOFTWARE / BIM / DOCUMENTATION**

- Web-based and user-friendly EUROVENT certified selection program
- BIM library

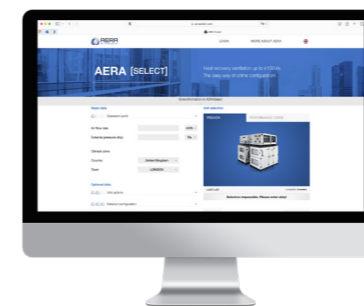

**EASY-TO-USE CONTROL SYSTEM**

- User-friendly, flexible advanced control with SENSO+ control system
- Language options: TR, ENG, FR
- Compatibility with BMS (Building Management System) via Modbus TCP/IP and Bacnet IP protocols
- Remote connectivity with AERA Cloud
- Communication with fire alarm panel
- Options for constant air volume (CAV), variable air volume (VAV), and demand-controlled ventilation (DCV)
- PID control

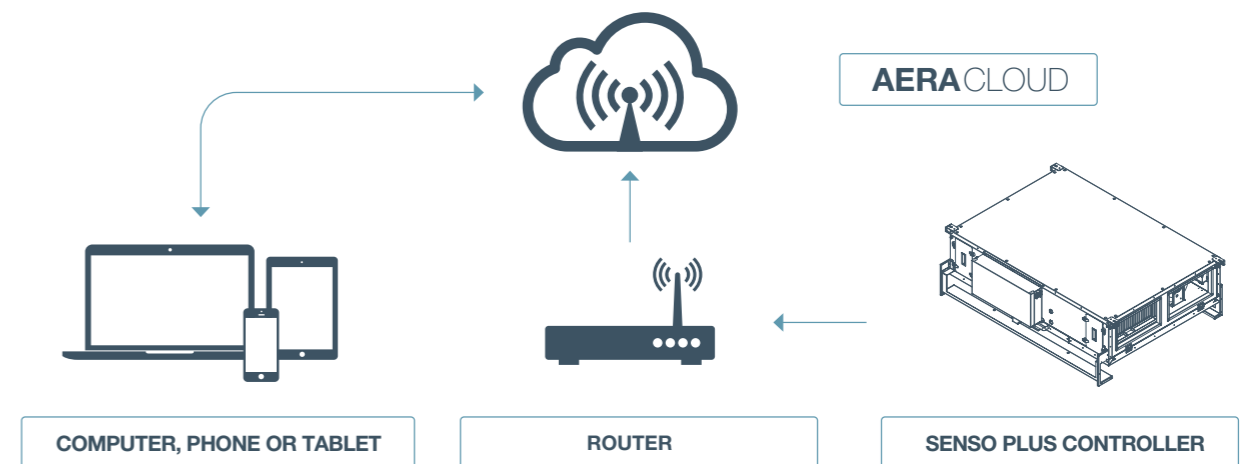



## Reference Standards

- EN 308
- EN 1886
- EN 13053
- EN 13779
- EU No 1253/2014 ECO-DESIGN
- EN 305
- ISO 5167-4:2003



**ANEMO**  
testlab

- EN 308
- EN 1886
- EN 13053
- EN 13779
- EU No 1253/2014 ECO-DESIGN
- EN 305
- ISO 5167-4:2003

## Intensive quality control

**ANEMO** AERA, committed to creating energy-efficient ventilation products, has developed its products in alignment with market expectations and demands. They have implemented robust quality management and quality control systems to ensure sustainability. Beginning with customer relationship management, we have made our management philosophy traceable, measurable and transparent, including design, procurement, production and after-sales services. Internal trainings and preventive activities are performed by evaluating the harvested data and are delivered as a part of our continuous improvement policy. At AERA, every product we manufacture undergoes rigorous quality control processes, starting from the component level, and is carefully monitored at every stage of production. The air handling units undergo testing and certification by independent organizations. Additionally, tests are conducted at the ANEMO laboratory in accordance with European norms and directives, guaranteeing consistent product quality.

Testing what is produced not only allows us to understand the quality of the existing product but also ensures the continuous improvement of future products.

At AERA, our commitment to quality is unwavering and central to our operations. We believe in delivering nothing less than the best to our valued customers. To achieve this, we implement a rigorous 100% quality control inspection on all our finished goods, ensuring that every product meets the highest standards. Recognizing the criticality of each stage in the assembly process, we've instituted a comprehensive checklist for pre-assembly processes. Every assembled part is meticulously checked before it progresses to the subsequent station, ensuring accuracy and excellence at every juncture. By continually monitoring and recording quality data, we gain invaluable insights into our strengths and areas that require enhancement. This approach not only aligns with the best practices of the HVAC industry but also sets a benchmark, reinforcing our constant endeavor to ensure that every product delivered to our customers is of the highest quality possible.



**ECO DESIGN** All manufacturers are legally obliged to follow ECO-DESIGN directives, which are a set of the European Union's regulations that state use of energy for energy-consuming products. LOT6 of the directive reviews the ventilation devices and air handling units and is effective in the European Parliament with the EU directive number 1253/2014 and 1254/2014. The ECO-DESIGN directives, prepared by the European Council for the purpose of replacing low energy-efficient products in the market with those of high efficiency, have been accepted as a prerequisite for CE marking with the dates specified and the entry of nonconforming devices into EU countries is prohibited. Within the scope of the ECO-DESIGN directive, which has been in force since January 1st 2016, a number of sub-limit values have been defined for air handling units, such as fan, heat recovery exchanger and filter efficiency. Thermal bypass and visual monitoring of filter arrestance has become compulsory with the directive also.

**All air handling units produced at AERA are designed and manufactured according to ECODESIGN criteria**



“Sustainability is no longer about doing less harm. It’s about doing more good .”

Jochen Zeitz



**EUROVENT CERTIFICATION**

Companies operating in the ventilation and air conditioning industry established the EUROVENT association and subsequently the association's certification body, Eurovent Certita Certification, to ensure that the performance of the units they produce can be evaluated based on common criteria, independent of local standards of countries. Today, with over 1000 members and offices in many parts of the world, EUROVENT is responsible for the certification and listing of many HVAC components such as Air Handling Units, Fan Coil Units, Roof Top Units, Chiller Units, and Air Conditioning devices through its 48 certification programs.

Air handling units are composed of components such as fans, water coils, heat recovery exchangers, filters, and humidifiers, brought together in different configurations. These components are placed inside a casing that possesses heat and sound insulation. The EUROVENT Certification program classifies the casing of the air handling unit according to the EN 1886 standard and approves thermal, acoustic, and electrical values in the data sheet created by the configuration and selection software by testing them according to EN 13053 standard.

According to EN 1886, the acoustic absorption, thermal bridging value, heat transfer coefficient, leakage values under negative and positive pressure, and deflection of the casing named MODEL BOX are measured. In EN 13053 tests, units' performance values are measured and compared with the selection data sheet. Additionally, the energy label value of the unit provided in the selection software is also approved.

**The AERA Compact air handling units can be selected on [www.aerselect.com](http://www.aerselect.com) and the AERA Modular Air Handling Units can be selected through the AERA HVACCalculator software; both have been verified as a result of tests conducted by EUROVENT. Moreover, all the Model Boxes in AERA's product portfolio have been tested according to EN 1886 and their performances have been documented.**



Compliance with hygienic requirements (used materials/ accessibility/cleanability) acc. to:  
 • VDI 6022-1  
 • VDI 3863-1  
 • DIN EN 13053  
[www.tuv.sud.com/health-him](http://www.tuv.sud.com/health-him)

**VDI 6022 HYGIENE CERTIFICATION**

Air handling units are designed and produced to introduce conditioned clean air into the indoor environment. Due to

temperature differences between the indoor and outdoor environments and the characteristics of the transferred air, bacteria and mold formation are observed in points where maintenance is not possible if the correct components are not used or due to errors in unit design. Especially since the 1980s, for air conditioning systems, to prevent the formation of bacteria causing Legionnaires' disease, all components except those made of metal inside the device need to be observed with the ISO 846 test for the absence of bacteria or mold formation. The German Engineers Association (VDI) guarantees safety of air handling units with VDI 6022 standard, which specifies hygiene conditions in air handling units, and does this through a certification program. During the certification process, while the components found inside the air handling units are approved against bacteria and mold formation with ISO 846 test, the body of the air handling unit is also tested and certified based on measures taken for cleanability and removal of condensation.

**AERA Compact air handling units have completed this certification process and have earned the VDI 6022 Hygiene certificate.**

AERA Compact air handling units have completed this certification process and have earned the VDI 6022 Hygiene certificate.



**SENSO+**

The advanced control system SENS PLUS in all Units, provides the most efficient control of all components which can be installed internally and as external accessories, ensuring the desired airflow conditions.

The SENS PLUS control also provides system control besides equipment control, which means that the devices can be operated with the Yearly Timer Function according to the working periods: Daily, Weekly, Monthly or Yearly.

In the Timer Function, values such as weekly working days, vacation times, daylight savings time can be defined and reported retrospectively.

Besides, the Support Function which is used to prevent the undesired conditions from occurring indoors even when the device is not working. The indoor temperature from falling below or exceeding a certain value even during non-working hours is ensured.

**INDOOR AIR QUALITY CONTROL**

The air quality sensor or the CO<sub>2</sub> sensor, which is placed in the critical volume or return channel in the interior, continuously measures the air quality. This value generates a signal that will change the EC fan fan speed by comparing it to the set point on the controller. If the indoor air quality is lower than the desired value, the fan speed and thus the fresh air amount is increased; if the indoor air quality is higher than the desired indoor air quality, the fan speed and fresh air speed are decreased; Energy saving is achieved in considerable amounts in heating or cooling loads caused by fresh air.

**CONSTANT FLOW CONTROL**

To meet the desired constant airflow requirement in the EVO Compact Air Handling Units, the SENS PLUS control measures the air pressure drop in the suction ports of the fans and compares the air flow with the set value to produce a working signal that will change the EC fan fan speed. Contamination of the filters can be controlled by static flow control within the fan operating curve, to the static pressure requirements of the unit which result in higher or lower than the project values.

**CONSTANT PRESSURE CONTROL**

In EVO Compact Air Handling Units, constant pressure control is used to meet the variable airflow requirement of the air duct system. The SENS PLUS control generates a working signal that will change the EC fan speed by continuously measuring the static pressure created in the supply air duct and comparing it with the value defined in the system. When a VAV damper opens or closes, higher or lower external static pressure needs can be met with constant pressure control within the fans operating curve. This way extreme noise in the ducts, unbalanced airflow distribution in different volumes is prevented.

**FILTERS**

The pressure drops of the filters used to clean the air, can be controlled by SENS PLUS control. Users are notified about the filter cleaning and replacement intervals. Pressure drop control can be made according to a constant pressure drop (Static) or variable air flow (Dynamic). Especially with units designed with variable speed fans, Dynamic Filter Control enables filter service at the right time.

**HEATING COIL**

Heating coils are used for increasing the supply air temperature and for bringing the supply air to the desired temperature after dehumidifying process. Hot water coils can be driven by proportional control via 2 or 3 way valves. With the SENS PLUS control, frost protection mechanism is available as standard to prevent the temperature of the supply water from reaching freezing conditions in extreme cold climates. If the return water temperature falls below a certain value set on the control, the heating valve is switched to the 100% open position and a run signal is sent to the heating water circulation pump. If the temperature still does not rise to the desired value, the device is stopped and the user is given a freeze alarm.

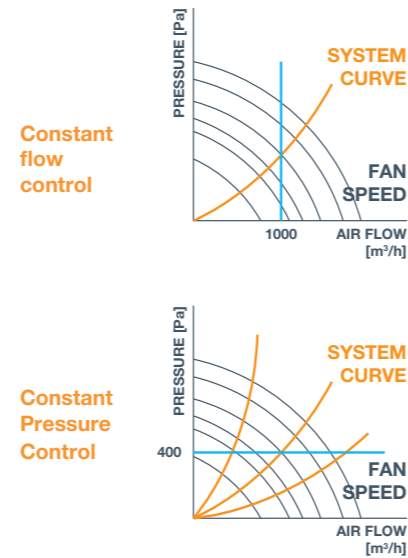

**COOLING COIL**

Externally mounted duct-type water cooling coils are used for such purposes as lowering the blowing temperature and dehumidifying the air in the units. It can be driven either proportionally or by on / off method.

**DX COIL**

Externally mounted duct type DX batteries are used for purposes such as lowering the supply air temperature, dehumidifying process and bringing the blown air to the desired temperature after dehumidification. It can be step controlled with on / off method, maximum 8 step setting is available.

**HUMIDITY CONTROL**

Humidity control equipments are used to raise or lower the humidity of the supply air. With the SENS PLUS control, the humidifier / de-humidifiers can be controlled to bring the supply air to the desired humidity value.



Everything is under your control with SENS PLUS

With the Cloud feature, the device's operating mode and settings can be changed and alarms can be monitored from any device connected to the internet.

**USER INTERFACE**

EVO ECO button control panel or EVO TOUCH touch screen control panel is offered with SENS PLUS. There is also a web server integrated into the card for monitoring and controlling the device via a computer. Control settings can be made via the server, and both current and historical operating values of the device can be monitored.

SENS PLUS control connects the web server over the internet and allows you to view and change the settings of your unit on any computer / tablet or mobile phone anywhere in the world. No need for complicated network settings, only a connected network cable is enough. With this feature, it is possible to monitor and control all units from different projects on a single screen, so that all of the operating values, active alarms, settings can be observed and remotely changed. Cloud control is an option provided with SENS PLUS, which is especially convenient when it is important to serve multiple devices within seconds, in different projects all around the world.

If desired, devices in different projects can be collected on a single screen and their operating values, active alarms, etc. can be displayed at the same time. It is possible to intervene by observing the values. This system, which provides great convenience especially in projects where multiple devices are used or when servicing many devices in different locations, is optionally provided with SENS PLUS.

**COMPLIANCE WITH INTERNATIONAL COMMUNICATION PROTOCOLS**

SENS PLUS control supports all of the universal communication protocols and interacts with other air handling units as well as with other building automation systems. ModBUS, BACnet and EXOline protocols are open as standard and there is also possibility to connect with LONWORKS protocol as an option.

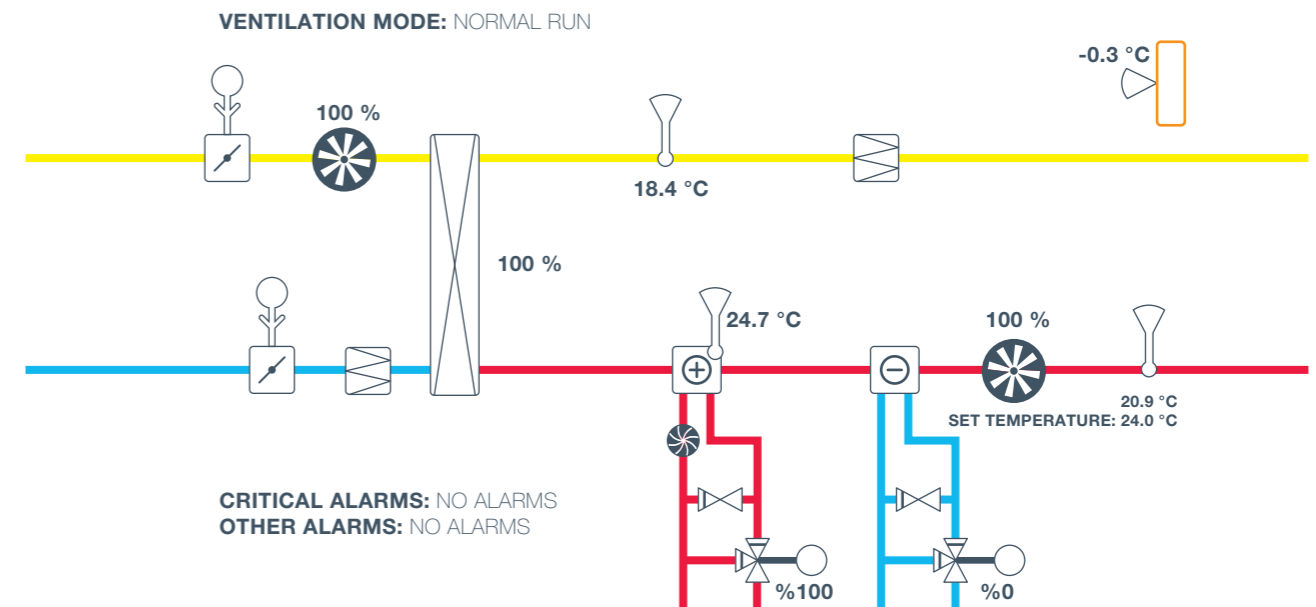



# VESTA HR

## CROSS FLOW HEAT RECOVERY VENTILATION

Heat recovery exchangers which are selected according to criteria that high efficiency and low pressure drop, plug fans suitable for Erp 2015 criteria, filters suitable for green building classification (LEED, BREEAM), resistive and compact structure are the main components of VESTA HR. Developed Senso automation system which is given together with the devices controls both ventilations functions and like heating/cooling air conditioning functions provided by accessories as a standard.

## CEILING TYPE HEAT RECOVERY UNIT WITH BYPASS

### CASING

- Inner sheets made of AZ 150 Aluzinc.
- Outer sheets made of galvanized steel with powder coating
- Insulated with 50 mm thick rock wool of 70 kg/m<sup>3</sup> density.
- Thermal transmittance T2, Thermal bridging class TB2.
- High air tightness

### HEAT EXCHANGER

- Counterflow heat recovery exchanger achieving up to 93% efficiency at nominal flow rates.
- Standard By-pass damper
- Free cooling capability.
- Exceptional air tightness between fresh air and exhaust air flows.

### FAN

- Superior aerodynamic efficiency.
- Low noise levels and energy consumption.
- Plug fans with IE4 efficiency class EC motors.
- Fan selection in compliance with ECO-DESIGN criteria.
- AC-powered, DC motor technology for speed control.



As VESTA HR devices are used;

- Fresh air is provided for outside to inside.
- Free cooling is done when conditions are met.
- Decreased quality of inside air is given to outside.
- Energy economy is provided by heat transfer between disposal air and fresh air.
- As the fresh air is filtered the air quality is increased.
- By the smart control system which is given together with the device controlling is provided according to user's varying needs.

### FILTER

- ECO-DESIGN compliant ePM1 55% (F7) class filter on the fresh air side, and ePM10 50% (M5) filters on the exhaust side, as standard.
- Dynamic filter cloaking measurement.
- Optional use of ePM1 80% (F9) filter for enhanced filtration performance.

### PLUG-PLAY

Design-in every aspect

- Integrated controls.
- Simplified installation.
- Swift commissioning.
- Convenience in attic solutions with its low height,

### CONTROLS & CONNECTIVITY

- Constant air volume (CAV), variable air volume (VAV), and demand-controlled ventilation (DCV) options.
- Optional indoor air quality control
- Temperature control.
- Humidity control.
- Standard Bacnet IP or Modbus TCP/IP BMS connections, with future connectivity option LONWORKS  
www.AERACLOUD.com Cloud Access
- Dry contact communication with fire alarm panel.





**CASING**

VESTA HR units are produced using polyester painted sheet metal with high corrosion resistance. Inside the unit, Aluminum and Zinc coated AZ 150 quality Aluzinc sheet metal is used. The casing is patented with its low pressure drop and high stability.

All components that require service, have their own service doors. This way the unit does not have to be disconnected from ducting system for servicing. Units are serviceable from left and right by design. This prevents problematic installations where service doors and electrical panel removals might cause.



**FILTER**

Air is cleaned with standard G4 type filters before it reaches any component in VESTA HR units. Low pressure drop filters have a rate of 98% when it comes to partial catching efficiency. Long lasting filters are easily cleaned with pressured air and after completing their lifecycle, they can be replaced easily. Optionally, F7 (MERV 13) filters can be used for if green building directives. High efficiency filters are produced especially for extending the surface area and reducing pressure drops. Filters fill up because of the particles they hold and this results in reduced air flow. In order to avoid dirty filters to affect air balance in the building, the unit has a filter cleaning alarm based on working hours.



**HEAT RECOVERY EXCHANGER**

The heat recovery exchangers are ocured by Aluminium plates which has high corrosion resistance in VESTA HR devices. In cross flow exchangers in order to increase the heat recovery efficiency and to decrease pressure drop, the plates are designed developed with engineering methods. Thus, it reaches the highest efficiency heat recovery exchanger performance values continuity is provided with EUROVENT certificate in their class. VESTA HR devices' heat recovery exchangers, have larger heat transfer surface up to 22-35% than competitors in market. The speed in air passing section is lower 11-29% than competitors in market also. Thus, by VESTA HR devices, high heat recovery efficiency and low pressure drop are provided.



**FAN**

VESTA HR units are designed with high energy efficiency, low sound pressure and low power consumption plug fans. All of our fans are compliant with ECO-DESIGN criteria by Eruopean Union Energy Comitee and ErP 2015. All of the fans are suitable for variable speed control. Fans up to VESTA HR 5000 are controlled with built-in SENSO control. They have 3 fixed speeds or stepless control with the help of an air quality sensor.

Vesta HR units use single phase AC motors up to HR50 and 3 phase AC motors up to HR60. Required electrical protection is taken with electronic components against high temperature or locked rotor.

**SENSO**

SENSO Smart Control which is specifically developed and adjusted for Ceiling Type devices, controls both standard components in device and componets attachable to ducts optionally to manage the desired supply air conditions. All of our devices works with plug and play logics are sent after complete comprehensive tests of control equipments and all components.



The basic functions provided by SENSO control in ventilation;

- Fan speeds are adjusted in 3 different speed independently
- Weekly time schedule
- Building automation connection (ModBUS)
- Preheater control (Step control)
- Afterheater Control
- Exchanger Freezing Control
- Battery Freezing Control (with Optional Sensor)
- Automatical BOOST Mode (with Optional Sensor)
- Automatical Flow Rate Control (with Optional Sensor)
- Filter Polution Control (with Optional Sensor)

**Room Control Panel**

The devices have a room control panel to adjust operating status easily. This user friendly interface panel can manage flow rate, heat settings, selection of operation mode, season selection, weekly time schedule easily and fast.

**Building Automation Connection**

SENSO control, works in interaction with other air conditioning devices and building automation systems via Modbus protocol.





## VESTA HR 07



### Fan Performance Curves

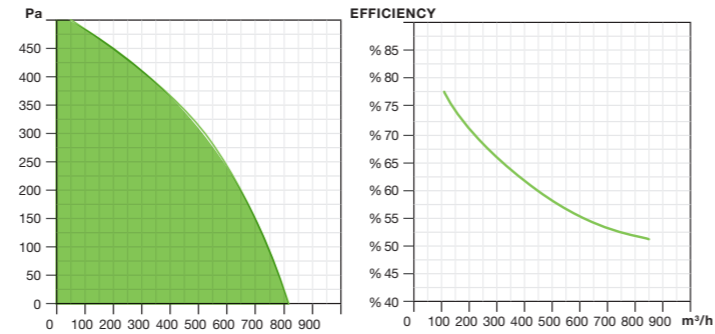

### UNIT DATA

Exchanger Type	Aluminum Plate Cross Flow
Fan Type	AC Plug Fan
ERP Conformity	ERP 2018
Installation Space	Indoor
Installation position	Horizontal
Service Side	Side and Bottom
Casing	10 mm Insulated Single Walled

### TECHNICAL DATA

Minimum Flow Rate (m³/h)	160
Nominal Flow Rate (m³/h)	810
Efficiency (-5°C OA, 22°C 50%RH RA)	56%
Weight (kg)	60
Fresh Air Filter	Coarse (G4)
Exhaust Air Filter	Coarse (G4)
Operational Temperature (1) (°C)	-12/+46

### Sound Data (2)

Sound Power Supply Air dB(A)	
Sound Power Exhaust Air dB(A)	
Radiated Sound 1m.	
Radiated Sound 3m.	
Radiated Sound 5m.	

### Electrical Data

BMS Communication	Modbus RTU
Supply Voltage	230V, 1~, 50 Hz
Max. Output Fans	
Nominal Current	1.2

<sup>(2)</sup>Nominal Air Flow, EN308

<sup>(3)</sup>Nominal Air Flow, Wet Conditions

### DIMENSIONS (mm)

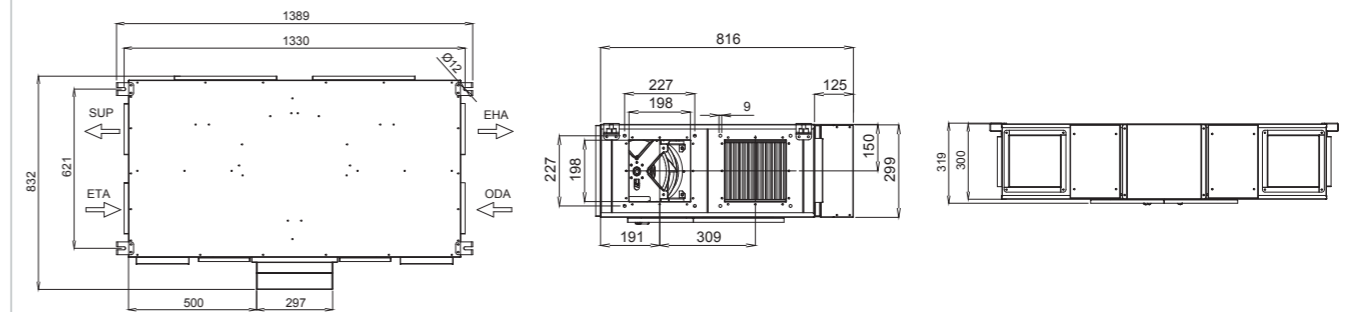

### ACCESSORIES

Electrical Pre-heater	Optional
Electrical After heater	Optional
Water After heater	Optional
Water Cooler	-
DX Coil	
Damper	
Weather Protection kit	
Supply Air Spigot	
Exhaust Air Spigot	
Drain Pump	
Ball Siphon	
HMI Type-1	
HMI Type-2	
Cloud Connection	
VOD Sensor, CO2	Optional
VOD Sensor, RH%	Optional
VOD Sensor, VOC	Optional
Signal Converter	Optional
Constant Pressure Kit	-
Exhaust Air Filter ePM10 50%	
Supply Air Filter (Pre-filter/ePM10 55%)	
Supply Air Filter ePM1 55%	
Supply Air Filter ePM1 80%	

You can find more information about accessories in the [ACCESSORIES](#) Section.



For our Current Certificates: [www.aera.com.tr](http://www.aera.com.tr)



## VESTA HR 12



### Fan Performance Curves

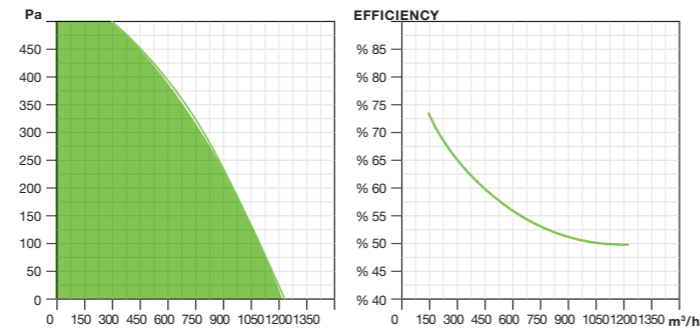

### UNIT DATA

Exchanger Type	Aluminum Plate Cross Flow
Fan Type	AC Plug Fan
ERP Conformity	ERP 2018
Installation Space	Indoor
Installation position	Horizontal
Service Side	Side and Bottom
Casing	10 mm Insulated Single Walled

### TECHNICAL DATA

Minimum Flow Rate (m³/h)	310
Nominal Flow Rate (m³/h)	1340
Efficiency (-5°C OA, 22°C 50%RH RA)	51%
Weight (kg)	75
Fresh Air Filter	Coarse (G4)
Exhaust Air Filter	Coarse (G4)
Operational Temperature (1) (°C)	-12/+46

### Sound Data (2)

Sound Power Supply Air dB(A)	
Sound Power Exhaust Air dB(A)	
Radiated Sound 1m.	
Radiated Sound 3m.	
Radiated Sound 5m.	

### Electrical Data

BMS Communication	Modbus RTU
Supply Voltage	230V, 1~, 50 Hz
Max. Output Fans	
Nominal Current	1.8

<sup>(2)</sup>Nominal Air Flow, EN308

<sup>(3)</sup>Nominal Air Flow, Wet Conditions

### DIMENSIONS (mm)

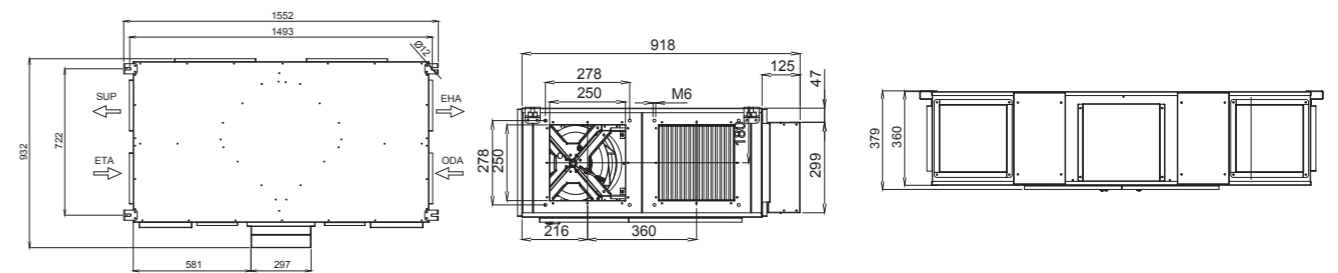

### ACCESSORIES

Electrical Pre-heater	Optional
Electrical After heater	Optional
Water After heater	Optional
Water Cooler	-
DX Coil	
Damper	
Weather Protection kit	
Supply Air Spigot	
Exhaust Air Spigot	
Drain Pump	Optional
Ball Siphon	Optional
HMI Type-1	
HMI Type-2	
Cloud Connection	
VOD Sensor, CO2	Optional
VOD Sensor, RH%	Optional
VOD Sensor, VOC	Optional
Signal Converter	Optional
Constant Pressure Kit	-
Exhaust Air Filter ePM10 50%	
Supply Air Filter (Pre-filter/ePM10 55%)	
Supply Air Filter ePM1 55%	
Supply Air Filter ePM1 80%	

You can find more information about accessories in the [ACCESSORIES](#) Section.



For our Current Certificates: [www.aera.com.tr](http://www.aera.com.tr)



## VESTA HR 15



### Fan Performance Curves

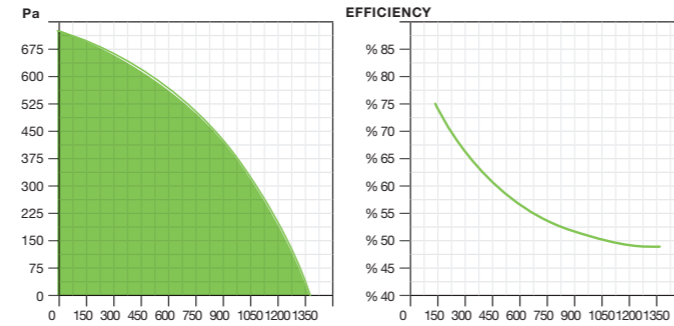

### UNIT DATA

Exchanger Type	Aluminum Plate Cross Flow
Fan Type	AC Plug Fan
ERP Conformity	ERP 2018
Installation Space	Indoor
Installation position	Horizontal
Service Side	Side and Bottom
Casing	10 mm Insulated Single Walled

### TECHNICAL DATA

Minimum Flow Rate (m³/h)	480
Nominal Flow Rate (m³/h)	1470
Efficiency (-5°C OA, 22°C 50%RH RA)	50%
Weight (kg)	88
Fresh Air Filter	Coarse (G4)
Exhaust Air Filter	Coarse (G4)
Operational Temperature (1) (°C)	-12/+46

### Sound Data (2)

Sound Power Supply Air dB(A)	
Sound Power Exhaust Air dB(A)	
Radiated Sound 1m.	
Radiated Sound 3m.	
Radiated Sound 5m.	

### Electrical Data

BMS Communication	Modbus RTU
Supply Voltage	230V, 1~, 50 Hz
Max. Output Fans	
Nominal Current	2,4

<sup>(2)</sup>Nominal Air Flow, EN308

<sup>(3)</sup>Nominal Air Flow, Wet Conditions

### DIMENSIONS (mm)

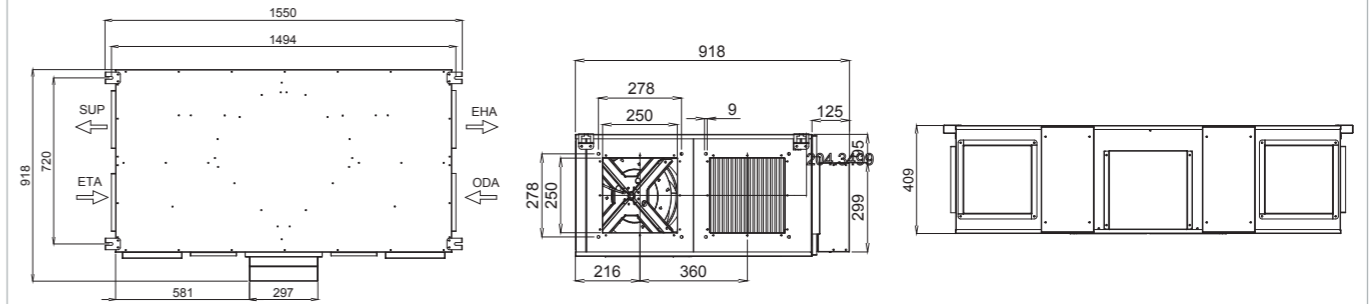

### ACCESSORIES

Electrical Pre-heater	Optional
Electrical After heater	Optional
Water After heater	Optional
Water Cooler	-
DX Coil	
Damper	
Weather Protection kit	
Supply Air Spigot	
Exhaust Air Spigot	
Drain Pump	Optional
Ball Siphon	Optional
HMI Type-1	
HMI Type-2	
Cloud Connection	
VOD Sensor, CO2	Optional
VOD Sensor, RH%	Optional
VOD Sensor, VOC	Optional
Signal Converter	Optional
Constant Pressure Kit	-
Exhaust Air Filter ePM10 50%	
Supply Air Filter (Pre-filter/ePM10 55%)	
Supply Air Filter ePM1 55%	
Supply Air Filter ePM1 80%	

You can find more information about accessories in the [ACCESSORIES](#) Section.



For our Current Certificates: [www.aera.com.tr](http://www.aera.com.tr)



## VESTA HR 20



### Fan Performance Curves

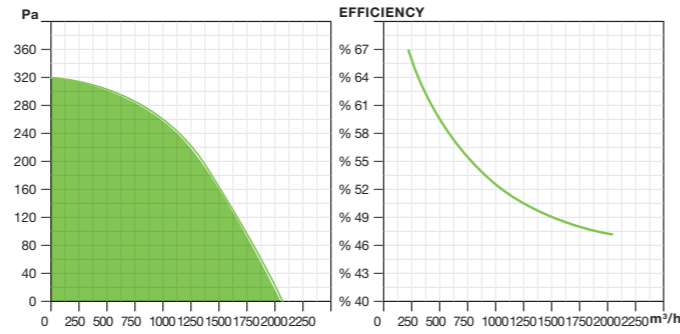

### UNIT DATA

Exchanger Type	Aluminum Plate Cross Flow
Fan Type	AC Plug Fan
ERP Conformity	ERP 2018
Installation Space	Indoor
Installation position	Horizontal
Service Side	Side and Bottom
Casing	10 mm Insulated Single Walled

### TECHNICAL DATA

Minimum Flow Rate (m³/h)	630
Nominal Flow Rate (m³/h)	2160
Efficiency (-5°C OA, 22°C 50%RH RA)	48%
Weight (kg)	110
Fresh Air Filter	Coarse (G4)
Exhaust Air Filter	Coarse (G4)
Operational Temperature (1) (°C)	-12/+46

### Sound Data (2)

Sound Power Supply Air dB(A)	
Sound Power Exhaust Air dB(A)	
Radiated Sound 1m.	
Radiated Sound 3m.	
Radiated Sound 5m.	

### Electrical Data

BMS Communication	Modbus RTU
Supply Voltage	230V, 1~, 50 Hz
Max. Output Fans	
Nominal Current	2,9

<sup>(2)</sup>Nominal Air Flow, EN308

<sup>(3)</sup>Nominal Air Flow, Wet Conditions

### DIMENSIONS (mm)

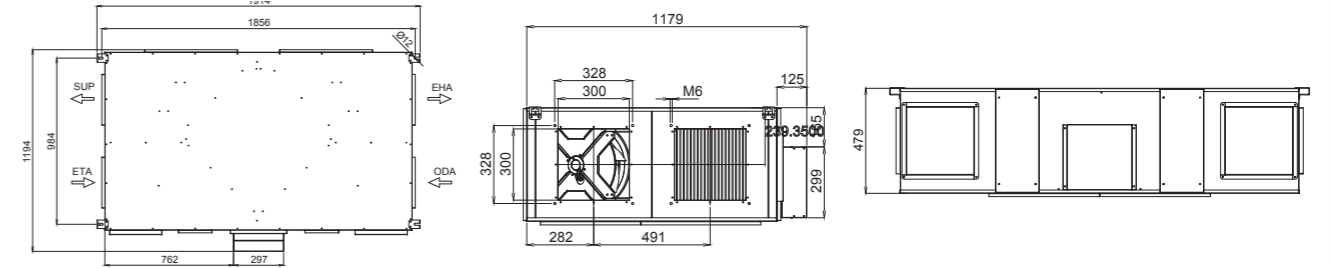

### ACCESSORIES

Electrical Pre-heater	Optional
Electrical After heater	Optional
Water After heater	Optional
Water Cooler	-
DX Coil	
Damper	
Weather Protection kit	
Supply Air Spigot	
Exhaust Air Spigot	
Drain Pump	Optional
Ball Siphon	Optional
HMI Type-1	
HMI Type-2	
Cloud Connection	
VOD Sensor, CO2	Optional
VOD Sensor, RH%	Optional
VOD Sensor, VOC	Optional
Signal Converter	Optional
Constant Pressure Kit	-
Exhaust Air Filter ePM10 50%	
Supply Air Filter (Pre-filter/ePM10 55%)	
Supply Air Filter ePM1 55%	
Supply Air Filter ePM1 80%	

You can find more information about accessories in the [ACCESSORIES](#) Section.



For our Current Certificates: [www.aera.com.tr](http://www.aera.com.tr)



## VESTA HR 30



### Fan Performance Curves

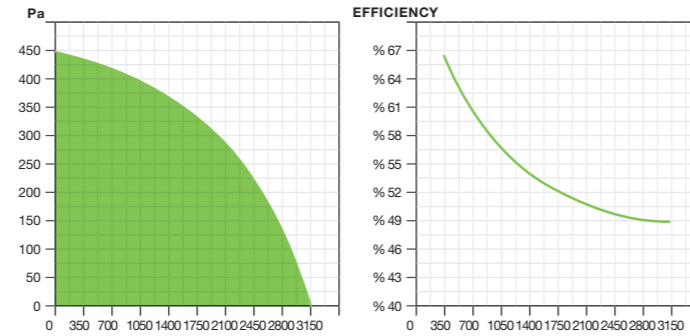

### UNIT DATA

Exchanger Type	Aluminum Plate Cross Flow
Fan Type	AC Plug Fan
ERP Conformity	ERP 2018
Installation Space	Indoor
Installation position	Horizontal
Service Side	Side and Bottom
Casing	10 mm Insulated Single Walled

### TECHNICAL DATA

Minimum Flow Rate (m³/h)	940
Nominal Flow Rate (m³/h)	3220
Efficiency (-5°C OA, 22°C 50%RH RA)	49%
Weight (kg)	140
Fresh Air Filter	Coarse (G4)
Exhaust Air Filter	Coarse (G4)
Operational Temperature (1) (°C)	-12/+46

### Sound Data (2)

Sound Power Supply Air dB(A)	
Sound Power Exhaust Air dB(A)	
Radiated Sound 1m.	
Radiated Sound 3m.	
Radiated Sound 5m.	

### Electrical Data

BMS Communication	Modbus RTU
Supply Voltage	230V, 1~, 50 Hz
Max. Output Fans	
Nominal Current	4,6

<sup>(2)</sup>Nominal Air Flow, EN308

<sup>(3)</sup>Nominal Air Flow, Wet Conditions

### DIMENSIONS (mm)

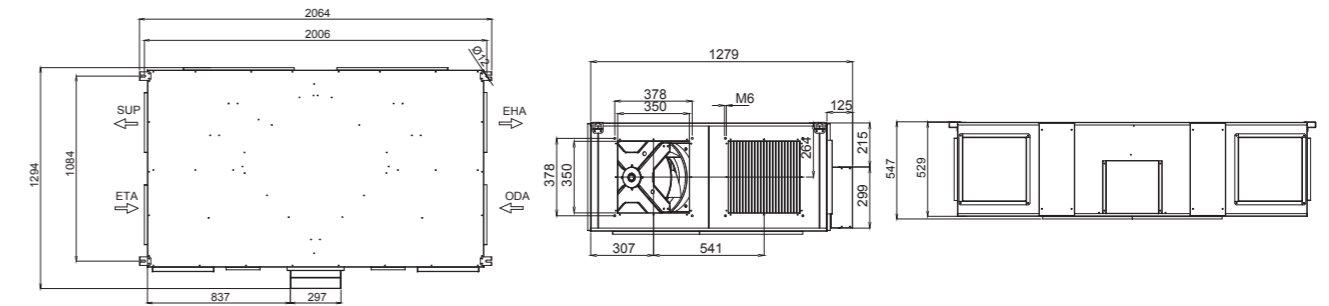

### ACCESSORIES

Electrical Pre-heater	Optional
Electrical After heater	Optional
Water After heater	Optional
Water Cooler	-
DX Coil	
Damper	
Weather Protection kit	
Supply Air Spigot	
Exhaust Air Spigot	
Drain Pump	Optional
Ball Siphon	Optional
HMI Type-1	
HMI Type-2	
Cloud Connection	
VOD Sensor, CO2	Optional
VOD Sensor, RH%	Optional
VOD Sensor, VOC	Optional
Signal Converter	Optional
Constant Pressure Kit	-
Exhaust Air Filter ePM10 50%	
Supply Air Filter (Pre-filter/ePM10 55%)	
Supply Air Filter ePM1 55%	
Supply Air Filter ePM1 80%	

You can find more information about accessories in the [ACCESSORIES](#) Section.



For our Current Certificates: [www.aera.com.tr](http://www.aera.com.tr)



## VESTA HR 40



### Fan Performance Curves

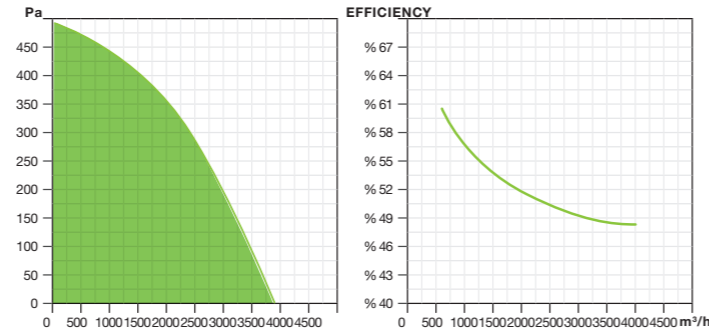

### UNIT DATA

Exchanger Type	Aluminum Plate Cross Flow
Fan Type	AC Plug Fan
ERP Conformity	ERP 2018
Installation Space	Indoor
Installation position	Horizontal
Service Side	Side and Bottom
Casing	10 mm Insulated Single Walled

### TECHNICAL DATA

Minimum Flow Rate (m³/h)	1140
Nominal Flow Rate (m³/h)	4200
Efficiency (-5°C OA, 22°C 50%RH RA)	49%
Weight (kg)	170
Fresh Air Filter	Coarse (G4)
Exhaust Air Filter	Coarse (G4)
Operational Temperature (1) (°C)	-12/+46

### Sound Data (2)

Sound Power Supply Air dB(A)	
Sound Power Exhaust Air dB(A)	
Radiated Sound 1m.	
Radiated Sound 3m.	
Radiated Sound 5m.	

### Electrical Data

BMS Communication	Modbus RTU
Supply Voltage	230V, 1~, 50 Hz
Max. Output Fans	
Nominal Current	4,8

<sup>(2)</sup>Nominal Air Flow, EN308

<sup>(3)</sup>Nominal Air Flow, Wet Conditions

### DIMENSIONS (mm)

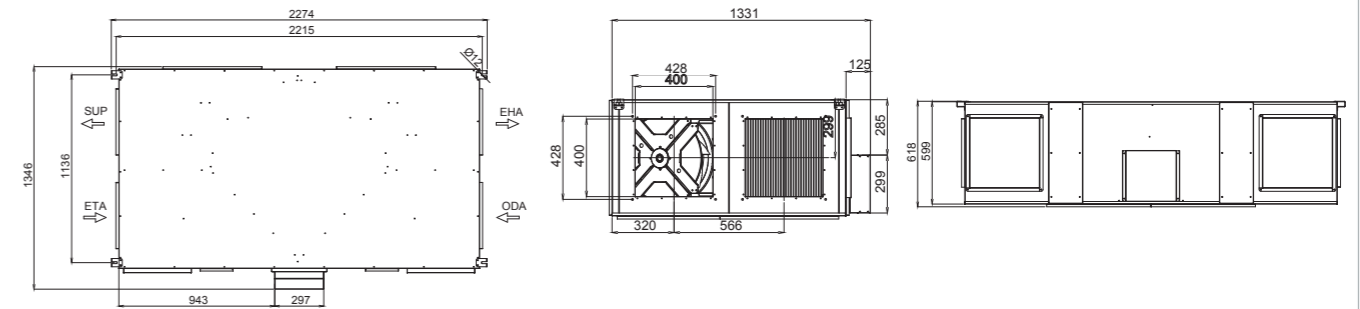

### ACCESSORIES

Electrical Pre-heater	Optional
Electrical After heater	Optional
Water After heater	Optional
Water Cooler	-
DX Coil	
Damper	
Weather Protection kit	
Supply Air Spigot	
Exhaust Air Spigot	
Drain Pump	Optional
Ball Siphon	Optional
HMI Type-1	
HMI Type-2	
Cloud Connection	
VOD Sensor, CO2	Optional
VOD Sensor, RH%	Optional
VOD Sensor, VOC	Optional
Signal Converter	Optional
Constant Pressure Kit	-
Exhaust Air Filter ePM10 50%	
Supply Air Filter (Pre-filter/ePM10 55%)	
Supply Air Filter ePM1 55%	
Supply Air Filter ePM1 80%	

You can find more information about accessories in the [ACCESSORIES](#) Section.





## VESTA HR 50



### Fan Performance Curves

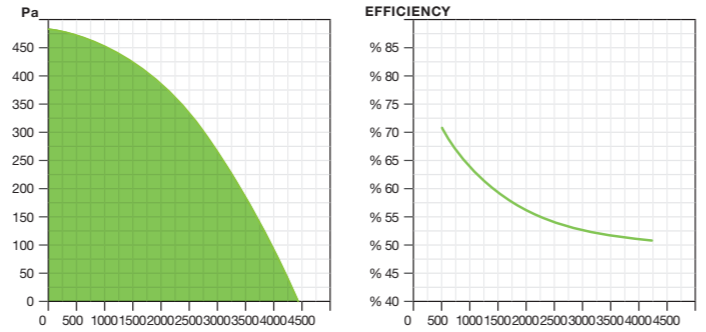

### UNIT DATA

Exchanger Type	Aluminum Plate Cross Flow
Fan Type	AC Plug Fan
ERP Conformity	ERP 2018
Installation Space	Indoor
Installation position	Horizontal
Service Side	Side and Bottom
Casing	10 mm Insulated Single Walled

### TECHNICAL DATA

Minimum Flow Rate (m³/h)	1270
Nominal Flow Rate (m³/h)	4950
Efficiency (-5°C OA, 22°C 50%RH RA)	51%
Weight (kg)	190
Fresh Air Filter	Coarse (G4)
Exhaust Air Filter	Coarse (G4)
Operational Temperature (1) (°C)	-12/+46

### Sound Data (2)

Sound Power Supply Air dB(A)	
Sound Power Exhaust Air dB(A)	
Radiated Sound 1m.	
Radiated Sound 3m.	
Radiated Sound 5m.	

### Electrical Data

BMS Communication	Modbus RTU
Supply Voltage	230V, 1~, 50 Hz
Max. Output Fans	
Nominal Current	5,4

<sup>(2)</sup>Nominal Air Flow, EN308

<sup>(3)</sup>Nominal Air Flow, Wet Conditions

### DIMENSIONS (mm)

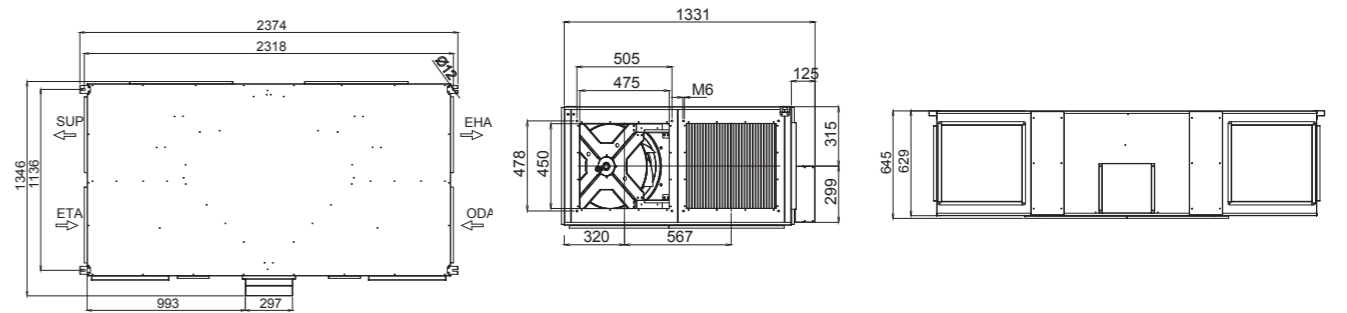

### ACCESSORIES

Electrical Pre-heater	Optional
Electrical After heater	Optional
Water After heater	Optional
Water Cooler	-
DX Coil	
Damper	
Weather Protection kit	
Supply Air Spigot	
Exhaust Air Spigot	
Drain Pump	Optional
Ball Siphon	Optional
HMI Type-1	
HMI Type-2	
Cloud Connection	
VOD Sensor, CO2	Optional
VOD Sensor, RH%	Optional
VOD Sensor, VOC	Optional
Signal Converter	Optional
Constant Pressure Kit	-
Exhaust Air Filter ePM10 50%	
Supply Air Filter (Pre-filter/ePM10 55%)	
Supply Air Filter ePM1 55%	
Supply Air Filter ePM1 80%	

You can find more information about accessories in the [ACCESSORIES](#) Section.



For our Current Certificates: [www.aera.com.tr](http://www.aera.com.tr)



## VESTA HR 60



### Fan Performance Curves

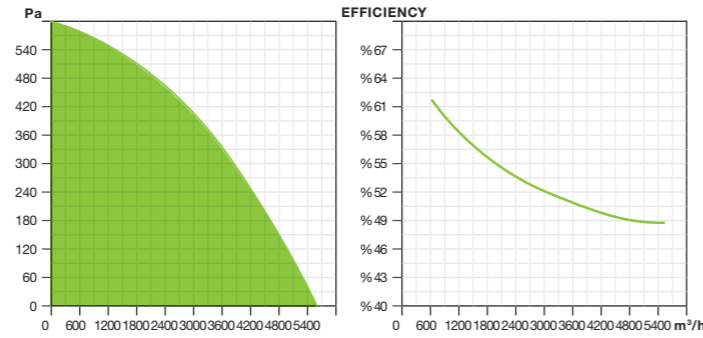

### UNIT DATA

Exchanger Type	Aluminum Plate Cross Flow
Fan Type	AC Plug Fan
ERP Conformity	ERP 2018
Installation Space	Indoor
Installation position	Horizontal
Service Side	Side and Bottom
Casing	10 mm Insulated Single Walled

### TECHNICAL DATA

Minimum Flow Rate (m³/h)	2240
Nominal Flow Rate (m³/h)	5640
Efficiency (-5°C OA, 22°C 50%RH RA)	49%
Weight (kg)	210
Fresh Air Filter	Coarse (G4)
Exhaust Air Filter	Coarse (G4)
Operational Temperature (1) (°C)	-12/+46

### Sound Data (2)

Sound Power Supply Air dB(A)	
Sound Power Exhaust Air dB(A)	
Radiated Sound 1m.	
Radiated Sound 3m.	
Radiated Sound 5m.	

### Electrical Data

BMS Communication	Modbus RTU
Supply Voltage	230V, 1~, 50 Hz
Max. Output Fans	
Nominal Current	3,8

<sup>(2)</sup>Nominal Air Flow, EN308

<sup>(3)</sup>Nominal Air Flow, Wet Conditions

### DIMENSIONS (mm)

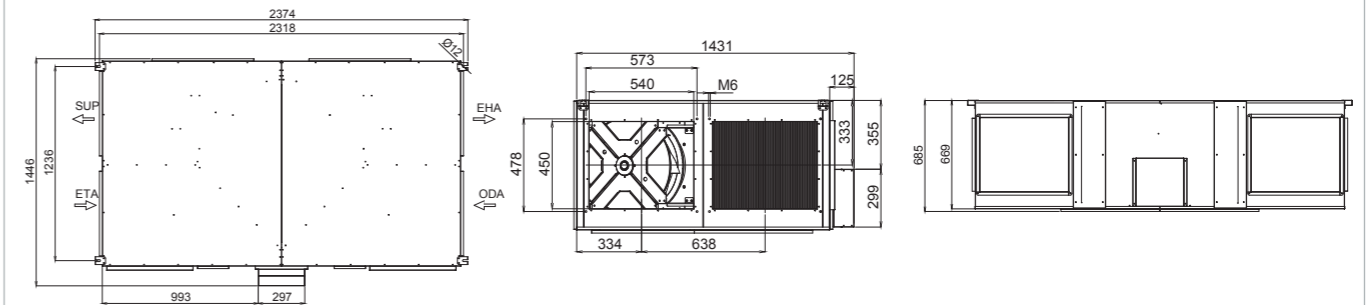

### ACCESSORIES

Electrical Pre-heater	Optional
Electrical After heater	Optional
Water After heater	Optional
Water Cooler	-
DX Coil	
Damper	
Weather Protection kit	
Supply Air Spigot	
Exhaust Air Spigot	
Drain Pump	Optional
Ball Siphon	Optional
HMI Type-1	
HMI Type-2	
Cloud Connection	
VOD Sensor, CO2	Optional
VOD Sensor, RH%	Optional
VOD Sensor, VOC	Optional
Signal Converter	Optional
Constant Pressure Kit	-
Exhaust Air Filter ePM10 50%	
Supply Air Filter (Pre-filter/ePM10 55%)	
Supply Air Filter ePM1 55%	
Supply Air Filter ePM1 80%	

You can find more information about accessories in the [ACCESSORIES](#) Section.





■ELECTRICAL PREHEATER

Used in order to prevent freezing at the exchanger in the situations which the outside air is very low. Controlled as a single step with SENSO control. Provides controllable energy efficiency with SENSO+ control via proportional signal.

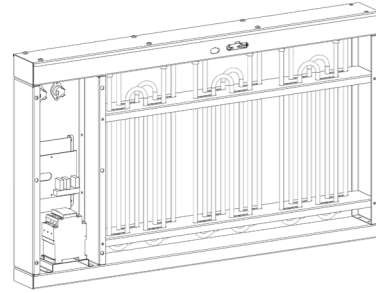

Model	Heater Capacity (kW)	Current (A)	Control
VT-PREH 07	1,2	5,2	On/off
VT-PREH-12	2	2,8	On/off
VT-PREH-15	2,4	3,4	On/off
VT-PREH-20	3	4,2	On/off
VT-PREH-30	4,5	6,3	On/off
VT-PREH-40	6	8,4	On/off
VT-PREH-50	7,5	10,5	On/off
VT-PREH-60	9	12,6	On/off

■ELECTRICAL AFTER HEATER

Used for increasing the supply air temperature. Operates automatically according to desired room temperature or desired supply temperature. Controlled as a single step with SENSO control. Provides controllable energy efficiency with SENSO+ control via proportional signal.

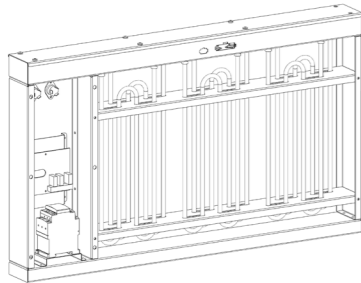

Model	Heater Capacity (kW)	Current (A)	Control
VT-POEH 07	1,2	5,2	On/off
VT-POEH-12	2	2,8	On/off
VT-POEH-15	2,4	3,4	On/off
VT-POEH-20	3	4,2	On/off
VT-POEH-30	4,5	6,3	On/off
VT-POEH-40	6	8,4	On/off
VT-POEH-50	7,5	10,5	On/off
VT-POEH-60	9	12,6	On/off

■WATER AFTER HEATER

Used for increasing the supply air temperature. Operates automatically according to desired room temperature or desired supply temperature. Controlled as a single step with SENSO control. Provides controllable energy efficiency with SENSO+ control via proportional signal.

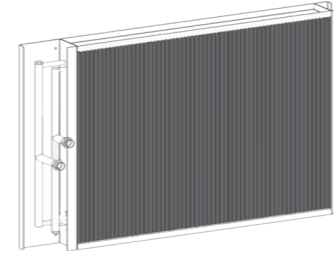

Model	Heater Capacity (kW)	Water Regime	Control
VT-POWH 07	1,2	80-60	On/off
VT-POWH-12	2	80-60	On/off
VT-POWH-15	2,4	80-60	On/off
VT-POWH-20	3	80-60	On/off
VT-POWH-30	4,5	80-60	On/off
VT-POWH-40	6	80-60	On/off
VT-POWH-50	7,5	80-60	On/off
VT-POWH-60	9	80-60	On/off

■Drainage Pump

Used when unloading the water occurred from condensation at the exchanger or battery cell in the device not possible via the present slope.

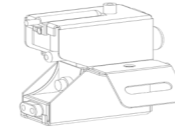

Model	Maximum Flow (l/h)	Max Head (m)	Max Suction Height (m)	Energy Supply
DP 01	13	10	1,5	230 V, 50/60 Hz
DP 02	40	10	2	230 V, 50/60 Hz

■SENSO HMI

The keypad user panel provides the communication with main PCB via the AERA-link protocol. Connection is made with 2x0.75 mm2 cable.



Model
SENSO HMI



### ■FILTER

In the projects, it is designed as a standard for more sensitive than the present filter's filtering

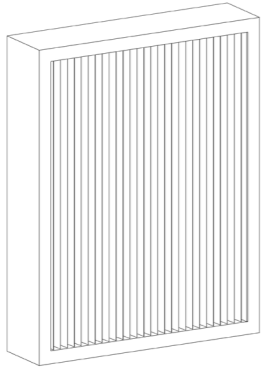
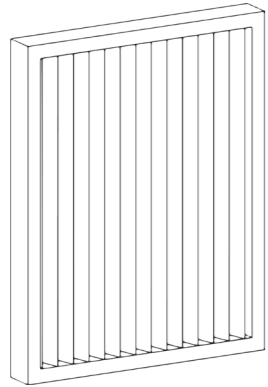

Model	Code
Egzoz Hava filtresi ePM10 50%	HR7EAEP10-50
	HR12EAEP10-50
	HR15EAEP10-50
	HR20EAEP10-50
	HR30EAEP10-50
	HR40EAEP10-50
	HR50EAEP10-50
Taze Hava filtresi ePM10 50%	HR60EAEP10-50
	HR7FAEP10-50
	HR12FAEP10-50
	HR15FAEP10-50
	HR20FAEP10-50
	HR30FAEP10-50
Taze Hava filtresi ePM1 55%	HR40FAEP10-50
	HR50FAEP10-50
	HR60FAEP10-50
	HR7FAEP1-55
	HR12FAEP1-55
	HR15FAEP1-55
	HR20FAEP1-55
	HR30FAEP1-55
	HR40FAEP1-55
HR50FAEP1-55	
HR60FAEP1-55	

### ■BALL SIPHON

Used for disposal of water In the heat recovery sections, the result of condensation at the exhaust air or the result of condensation at the cooking batteries. Can operate in both positive negative pressure.

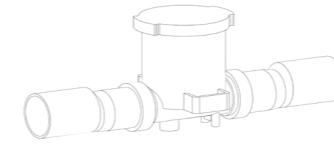

Model
SIPH

### ■VOD

Located in inside of critical volume or return duct, the optional air quality sensor ( VOC or CO2 ) or relative humidity sensor (RH%) consistently measures the air quality or relative humidity. This value, as being compared with set value which is arranged on control, creates operating which changes EC fan's fan speed. If the air in room is lower than desired air quality or the relative humidity is higher than the desired value, the fan speed is increased so, fresh air amount increased, if the air in room is higher than desired air quality or the relative humidity is lower than the desired value, the fan speed is decreased so, fresh air amount decreased; Thus, a significant energy save is provided at the heating or cooling loads caused by the fresh air.



Model	Measurement	Installation Position
VOD-VOC-RM	VOC	Room
VOD-VOC-DUCT	VOC	Channel
VOD-CO <sub>2</sub> -DUCT	CO <sub>2</sub>	Room
VOD-CO <sub>2</sub> -RM	CO <sub>2</sub>	Channel
VOD-RH-DUCT	RH%	Room
VOD-RH-RM	RH%	Channel
PS-MW	-	-

### ■Signal Converter

SENSO<sup>+</sup> devices as make an access that connect up to 3 VOD sensors, both measure gas and different volume gases, change the capacity according to these measurements of air conditioning plants. Via Signal Converter, in 3 different types, for each type up to 6 measurements or obtained values from 18 different measurement volumes are used for controlling air conditioning plant is provided.



Model
SENSO+ SK









**AERA Air Conditioning Ventilation  
Technologies Corporation**

**Factory I:** 14. Cadde, No:13, Pancar OSB

**Factory II:** 3. Cadde, No:13, Pancar OSB

Torbalı/İzmir-Türkiye, +90 232 799 01 11

**E-mail:** sales@aera.com.tr

**Sales Headoffice:** Özdemir Sok. Kurtuluş Apt. No: 5

Kadıköy/İstanbul-Türkiye, +90 216 504 76 86



[aera.com.tr](http://aera.com.tr)